

User Manual



MF Filter-Table/Low. F9- or HEPA H13 Filter Box.

- **Downdraft Filter-Table for Sitting Work Position. "Plug and Play".**
- **Fume and Dust is extracted downwards instead of being inhaled.**
- **Models with F9 Filter Box (9m²) or HEPA H13 Filter Box (9m²).**
- **F9 Models Suitable for filtration of light welding fume and light dust.**
- **HEPA H13 Models for light Stainless Steel welding and Fine Dust.**
- **Can be equipped with Side- and Back Panels with "Quick Release".**
- **Height adjustable 0.65-0.8m.**
- **Clean Air Outlet at the Bottom of the Unit.**
- *** Castors are Accessories. Height adjustable Legs are standard.**

MF Filter-Tables/Low with different Tops and Back/Side Panels .



Basic with Feet.
Table 0.7m(D)x0.6m(W).



Basic with Feet.
Table 0.7m(D)x0.9m(W).



Basic+Castors.
Table 0.7m(D)x0.6m(W).



With 0.2m high Back/Side Shields.
Table 0.7m(D)x0.6m(W).



With 0.2m high Back/Side Shields.
Table 0.7m(D)x0.9m(W).



As to the left+Castors.
Table 0.7m(D)x0.6m(W).



With 0.4m high Back/Side Shields.
Table 0.7m(D)x0.6m(W).



With 0.4m high Back/Side Shields.
Table 0.7m(D)x0.9m(W).



As to the left+Castors.
Table 0.7m(D)x0.6m(W).



"Quick Release".

The Side Panels can be demounted in seconds. Just lift and pull back and it will be loose.

Table of Contents

1.0 General Information

1.1 Safety Note

1.2 Range of Application

1.3 Unit Description

1.4 Measures

1.5 Mounting

1.6 Change of Filter

2.0 Maintenance

2.1 General Information

2.2 Spare Parts

1.0 General Information.

A MF Downdraft Filter-Table Low is an easy and efficient way to create a work friendly booth with clean air.

The Low models are for a sitting work position. The table top of 4mm thick steel is either 0.6m(W)x0.7m(D) or 0.9mx0.7m.

The table top height can be adjusted from 0.65m-0.8m and can be equipped with side and back shields, 200 or 400mm high. Always an ergonomical work position

The unit is simple to install. Just plug it into an electric socket. Ready for use! The contaminated air is exhausted downwards and not inhaled. Then the cleaned air is returned to the room at the bottom of the unit.

MF Downdraft Filter-Tables can be used for all sort of work where extraction and filtration of fume and dust is needed. Perfect for light welding and grinding in schools and other places where light dust and fume is generated.

The models with HEPA H13/W3 filter box are suitable for light stainless steel welding and very fine dust.

The F9 and HEPA H13 Filter boxes are both equipped with an Alu Mesh prefilter which is washable.

The Door has 4 expander locks to make it easy to open and lock. 4 locks makes sure that the door is tight.

To replace the filter box you open the door and pull it out and replace it with a new. The Alu Spark Trap on top of the box shall be cleaned and reused.

1.1 Safety Note

Always disconnect the electricity supply before opening the Filter-Table.

Don't exhaust Sparks or Poisonous Dust.

Use adequate safety clothing when replacing dirty filter boxes. Dispose of used filter Boxes/cartridges according to local laws and regulations.

1.2 Range of Application.

The MF Filter-Table is designed for being a work-table and work both with clean. It is for indoor use. The F9 model has an filtration of 99% and the HEPA H13/W3 of 99.95%. The cleaned air can be recirculated into the room as long as it is not against local laws and regulations.

1.3 Unit Description

MF-F9 or MF-HEPA Filter-Tables (Low). For Sitting Work Position.



Basic with Legs incl.

200mm high Shields

400mm high Shields

Complete Work Station with Table and Clean Air. Sitting Work Position.

MF-F9 and MF-HEPA Filter-Tables/Low are complete “Plug and Play” workstations for sitting work position. It will solve your “Health and Safety” problems. Perfect for all sorts of Light Welding, Grinding and Soldering. Just place it where it is needed and “Plug it in”. Dust and Fume will be extracted downwards and **will not be inhaled** by the operator. It will be cleaned by the built in F9 Filter or HEPA H13/W3 Filter and be returned to the premises (Check with Authorities).

F9 or HEPA H13 Filters. For welding/soldering in Normal Steel is MF-F9 with F9 Filter Box (9m²) recommended. For Stainless Steel you have to have MF-HEPA H13/W3 Filter Box (9m² with 99.95% Efficiency). The MF Filter-Tables are designed for light welding/soldering and light dust.

Adjustable Table Height and 2 Table Sizes. 4mm thick Table.

The MF Filter-Table/Low is as standard equipped with height adjustable legs. The Table Height is adjustable from 0.65-0.8m. Always a Comfortable and Ergonomic work position. There are 2 table sizes: 0.6m(W)x0.7m(D) and 0.9m(W)x0.7m(D). Can be equipped with heavy duty castors (P-956).

Side- and Back Shields.

The MF Filter-Table can be equipped with 200mm or 400mm high Back and Side Shields (Accessory). The Side Shields can be put up/down in seconds with the “Quick Release”.

Art. No.

MF-F9 Filter-Table/Low. 1-Ph./1.1Kw/220V/50Hz, Filter Box F9 (10m²). 0.6m(W)x0.7m(D)	P-972
MF-F9 Filter-Table/Low. 1-Ph./1.1Kw/220V/50Hz, Filter Box F9 (10m²). 0.9m(W)x0.7m(D)	P-973
MF-HEPA Filter-Table/Low.1-Ph./1.1kW/220V/50Hz, Filter Box HEPA H13 (9m²) 0.6m(W)x0.7m(D)	P-974
MF-HEPA Filter-Table/Low.1-Ph./1.1kW/220V/50Hz, Filter Box HEPA H13 (9m²) 0.9m(W)x0.7m(D)	P-975
Back- and Side Shields 200mm high for Table 0.6m(W)x0.7m(D)	P-930
Back- and Side Shields 400mm high for Table 0.6m(W)x0.7m(D)	P-931
Back- and Side Shields 200mm high for Table 0.9m(W)x0.7m(D)	P-937
Back- and Side Shields 400mm high for Table 0.9m(W)x0.7m(D)	P-938
F9 Replacement Filter Box 10m². For MF Filter-Tables (low).	P-976
HEPA H13/W3 Replacement Filter Box 9m². For MF Models High/Low (Not for ECO Models)	P-967
Heavy Duty Castors with Brakes (125mm) 4 pcs. Fits directly on MF Filter-Table or on the Legs.	P-956
Holder for Welding Gun. Can be mounted to the right/left of all MF and MF-Eco Filter tables.	P-932

Description: MF Filter-Table/Low "Basic".

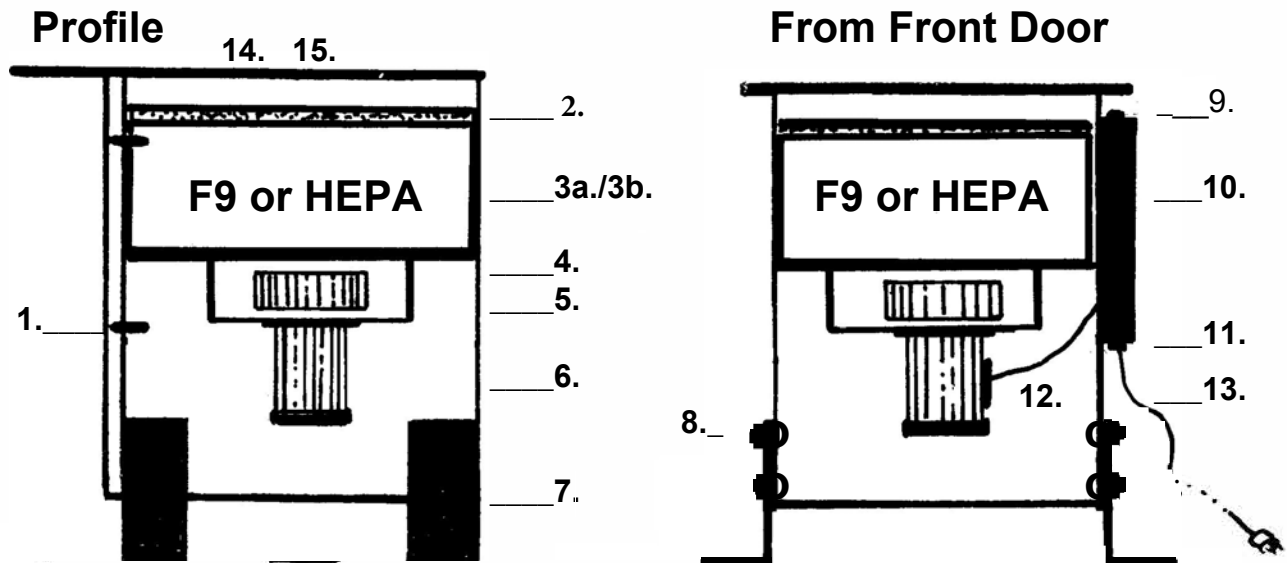

1. Door with 4xExenter Lock.
2. Pre-Filter of Alu Mesh. Washable.
3. 3a. F9(10m²) Filter Box. 3b. HEPA H13(9m²) Filter Box.
4. Fan Impellar.
5. Fan Housing.
6. Electric Motor.
7. Legs height adjustable 150mm.
8. Coach Bolts M8x16mm 16 pcs. with 16 M8 Locking Nuts for the Legs.
NOTE! Bolt Heads from the Inside!
9. Electric on/off Switch with Overload Protection.
10. Electric Box with 2xM8x35mm Bolts.
11. Cable Gland.
12. Motor Cable.
13. Cable with Plug.
14. Table Top 0.7m(D)x0.6m(W)x4mm with 6xM6x16mm Hex Socket Countersunk Bolts.
15. Table Top 0.7m(D)x0.9m(W)x4mm with 6xM6x16mm Hex Socket Countersunk Bolts.

Description: Accessories MF Filter-Table.

Back/Side Shields/200mm high.

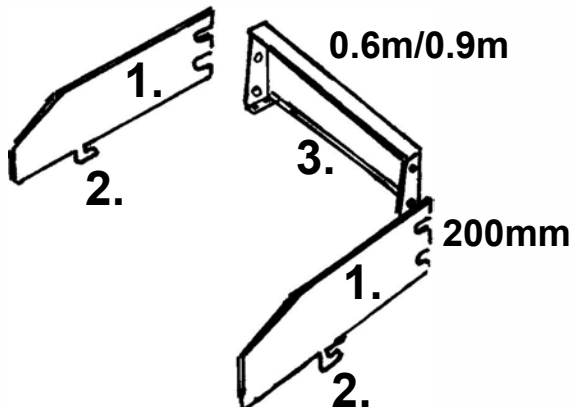

Back/Side Shields/400mm high.

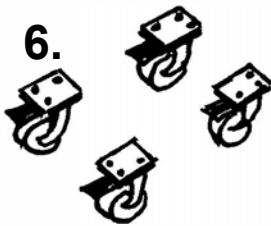
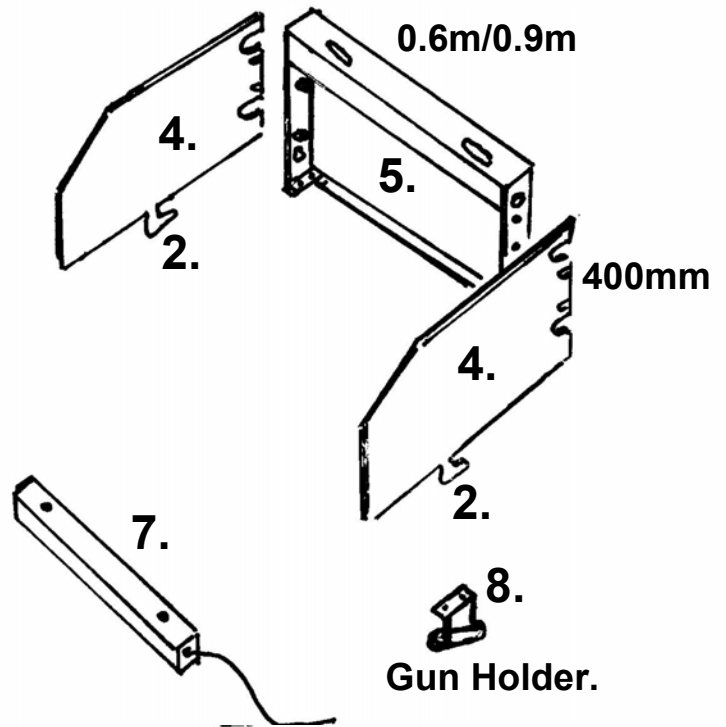

4xCastor.

Flouroscent Light.

Gun Holder.

1. Quick Release Side Shield/200mm high.
2. Quick Release Hook fits in Hole on Table Top.
3. 3a. Back Shield 0.6m wide/200mm high.
3b. Back Shield 0.9m wide/200mm high.
4. Quick Release Side Shield/400mm high.
5. 5a. Back Shield 0.6m wide/400mm high.
5b. Back Shield 0.9m wide/400mm high.
6. Castor 125mm high with Brake. 360 Degree.
7. Flouroscent Light for 400mm high Back Shield.
8. Holder for Welding- or Compressed Air Gun.
Can be mounted to the Right or to the Left
of the Table Top.

1.4 Measures (mm) MF Filter-Table/Low F9 or HEPA H13.

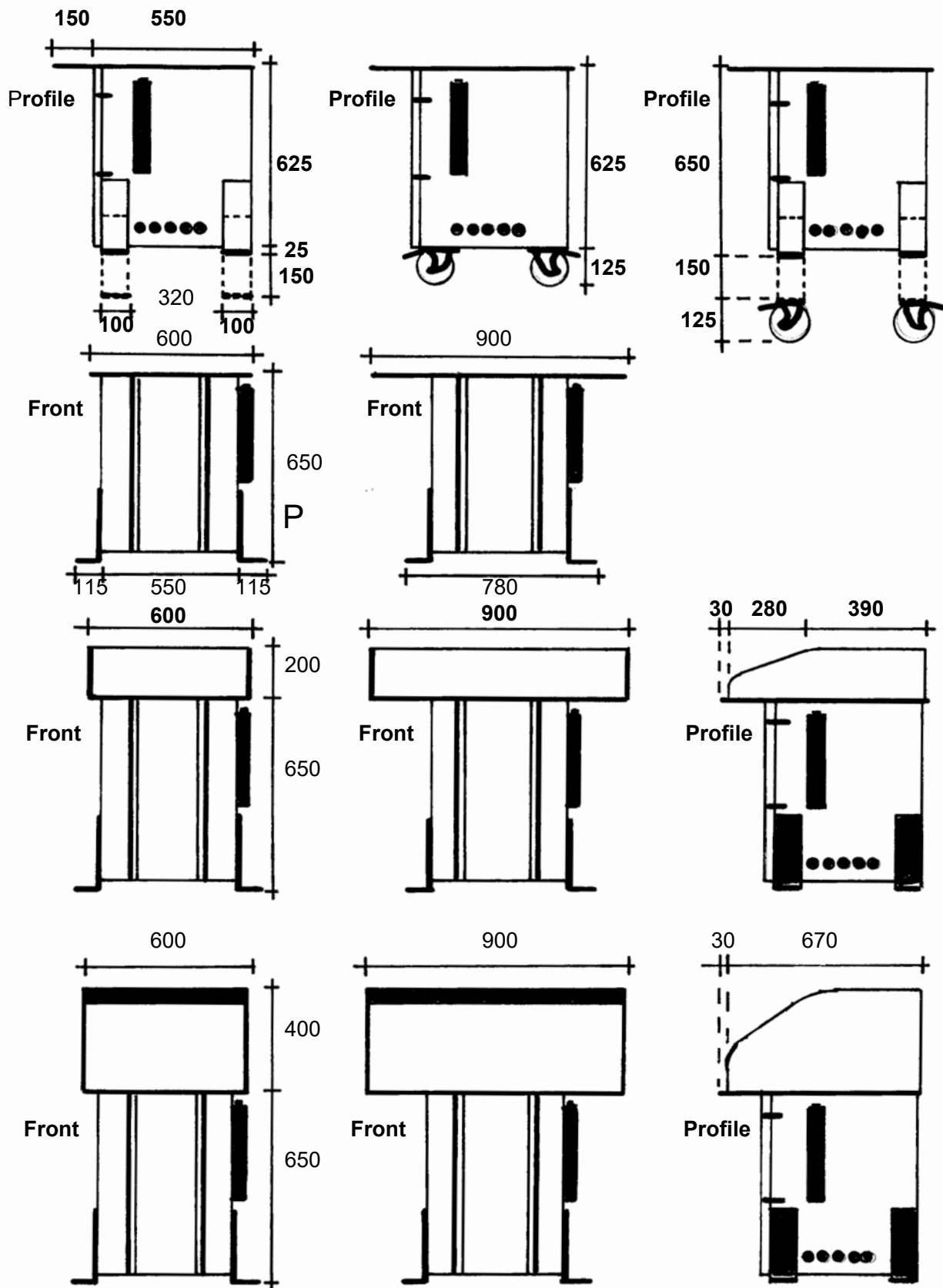

1.5 Mounting Instruction MF Filter-Table/Low F9 or HEPA.

Delivery:

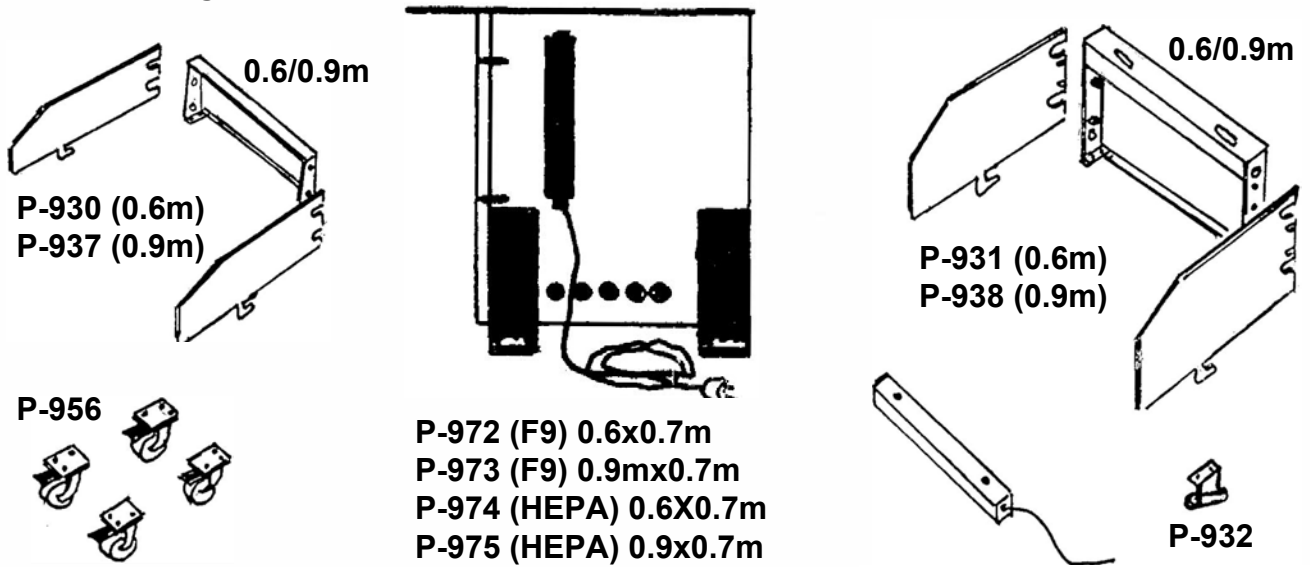

Height adjustment

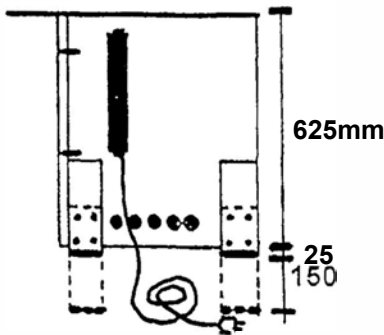

Mounting of Castors

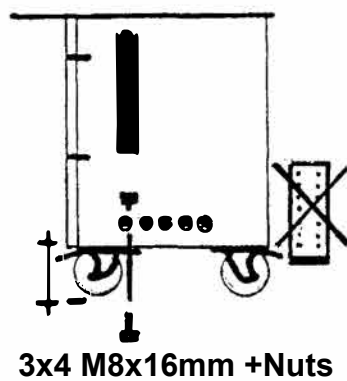

Mounting of Castors on adjustable Legs

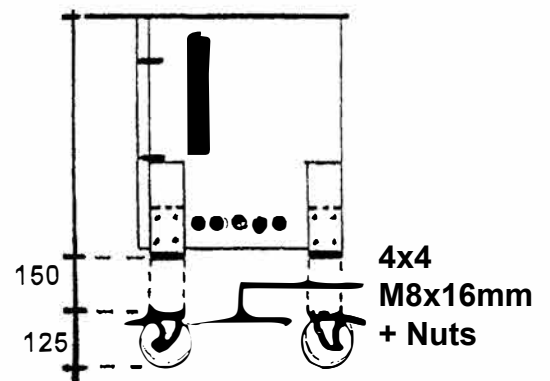

Fix to Floor

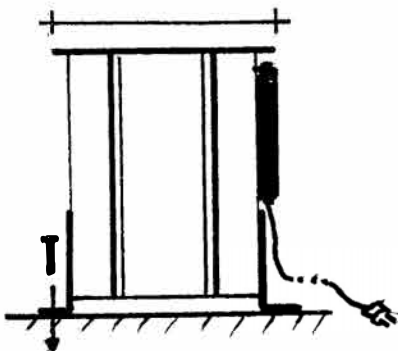

Mounting of 0.6m Back Shield

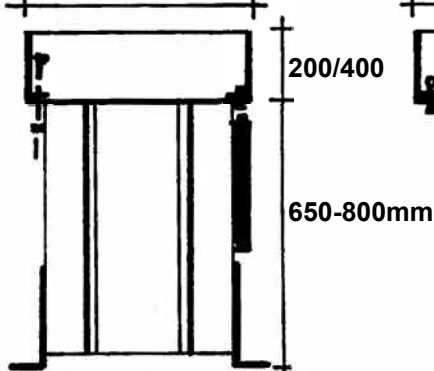

Mounting of 0.9m Back Shield

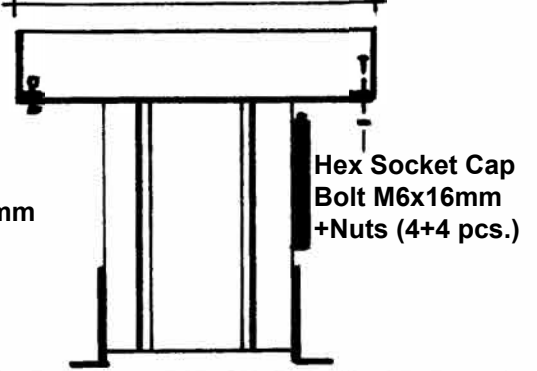

Mounting of Quickrelease Side Shields

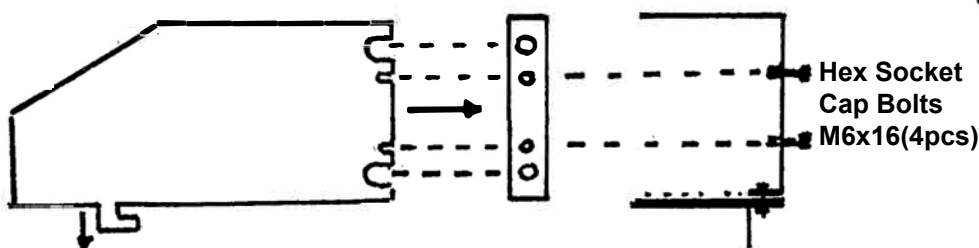

Push the Shield until the small slots can slide over the Bolts. Let the Hook go down into the slot in the table. Push forward until stop. Tighten the Bolts light.

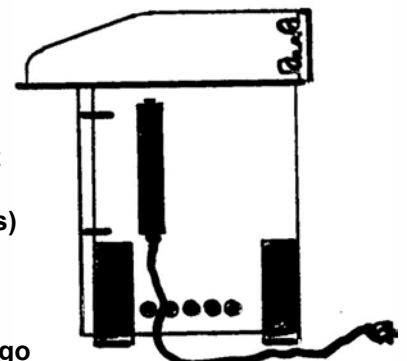

1.6 Change of Filter: MF Filter-Table/Low F9 or HEPA H13.

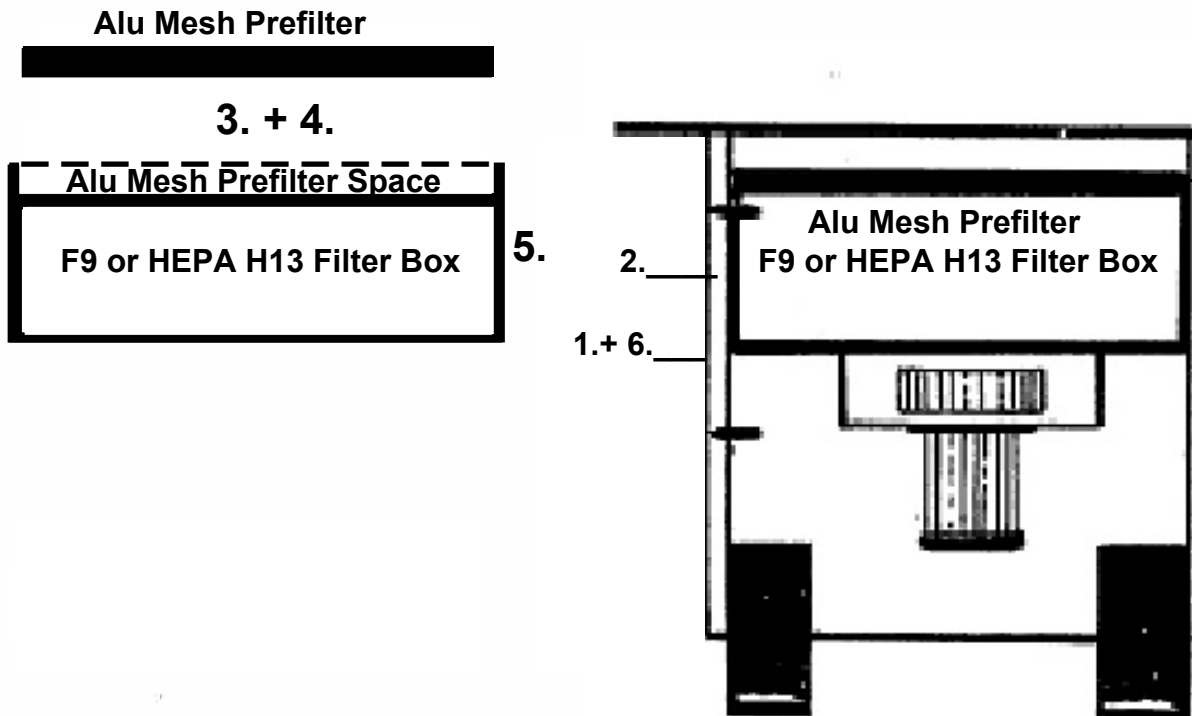

Switch off the Fan and Use adequate safety Clothing.

Recommended Steps to Replace a Filter Box and the Alu Mesh Filter.

1. Open the 4 Exenter Locks on the Door and lift it off.
Place it in a safe Place.
2. Pull out the F9 Filter Box or the HEPA H13 Filter Box, which has the Alu Mesh Filter inside of the Top.
3. Take out the Alu Mesh Filter and clean/wash it.
4. Place the cleaned/washed Alu Mesh Filter in the top of a Replacement F9 or HEPA H13 Filter Box. Be sure it is in the side **WITHOUT SEAL**.
5. Put the Filter Box with the Alu Mesh Filter back into the Filter-Table.
Note that the **SEAL** shall be **DOWNWARDS!!**
6. Replace the Door and lock it with the 4 Exenter Locks.
7. The MF Filter-Table is now ready for use again.
8. Dispose of the old Filter Box according to Local Laws and Regulations.

2.0 Maintenance

2.1 General Information.

The MF Filter-Tables are robust and normally don't need much maintenance. However the following should be checked at least 2 times a year.

- 1. Check that all bolts are tight.**
- 2. Check if the extraction is good enough. If not clean/wash the Alu Mesh Prefilter and replace the F9 or HEPA H13 Filter Box. See "2.2 Change of Filter. There is no Problem with changing from F9 to HEPA H13 Filter Box or vice versa if you want to.**
- 3. Check the Electric Cable. If there are damages on it you have to change it. Use Plymoth original spare parts.

A certified Electrician has to do the change.**
- 4. Check with the Operator that the table height is comfortable. If not adjust the height of the Legs.**

2.2 Spare Parts: MF Filter-Table/Low "Basic".

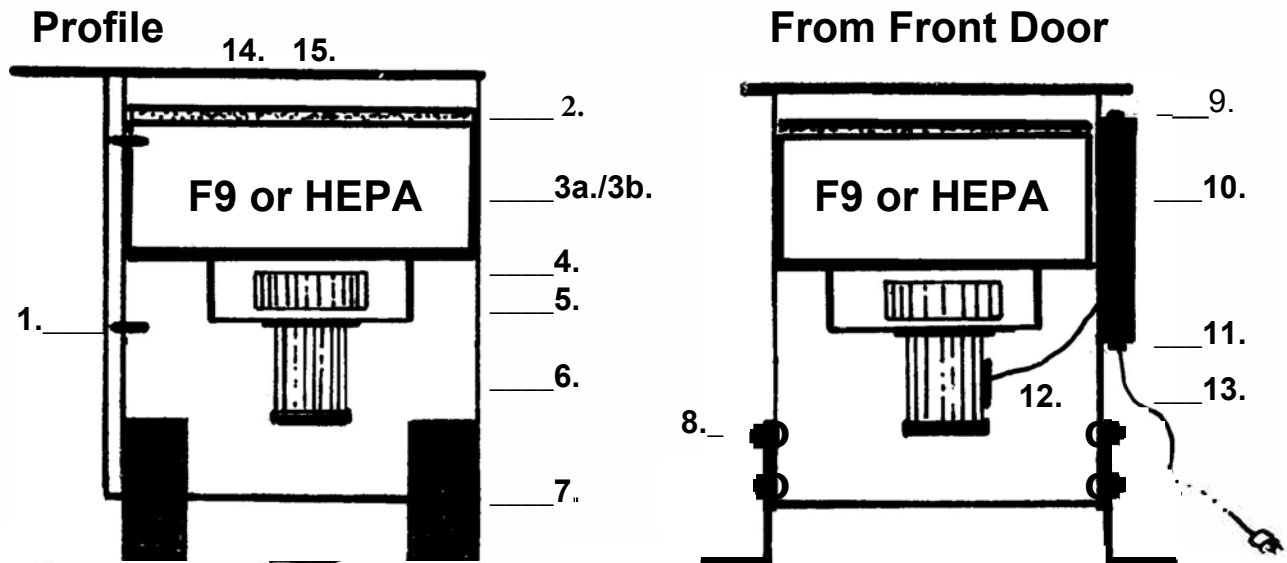

When ordering Spare Parts please specify:

- a. Name and P-number of Your Product.
- b. Number and Text from below.
- c. Quantity of each Spare Part.

1. Door with 4xExenter Lock, complete.
2. Pre-Filter of Alu Mesh. Washable.
3. 3a. F9(10m²) Filter Box.
3b. HEPA H13(9m²) Filter Box.
4. Fan Impellar.
5. Fan Housing.
6. Electric Motor 1-phase/1.1kW/220V/50 Hz.
7. Legs height adjustable 150mm.
8. Coach Bolts M8x16mm 16 pcs. with 16 M8 Locking Nuts for the Legs. **IMPORTANT!! Bolt Heads from the Inside!**
9. Electric on/off Switch with Overload Protection.
10. Electric Box with 2xM8x35mm Bolts.
11. Cable Gland for d. 20mm Hole.
12. Motor Cable from Motor to on/off Switch.
13. Cable with Plug.
14. Table Top 0.7m(D)x0.6m(W)x4mm (Unpainted), with 6xM6x16mm Hex Socket Countersunk Bolts.
15. Table Top 0.7m(D)x0.9m(W)x4mm (Unpainted), with 6xM6x16mm Hex Socket Countersunk Bolts.

Spare Parts: Accessories MF Filter-Table Low/High.

Back/Side Shields/200mm high.

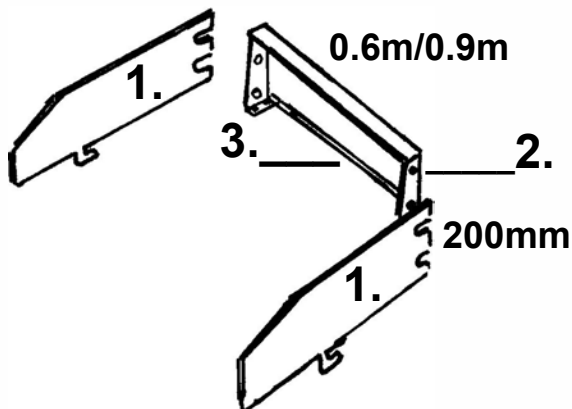

Back/Side Shields/400mm high.

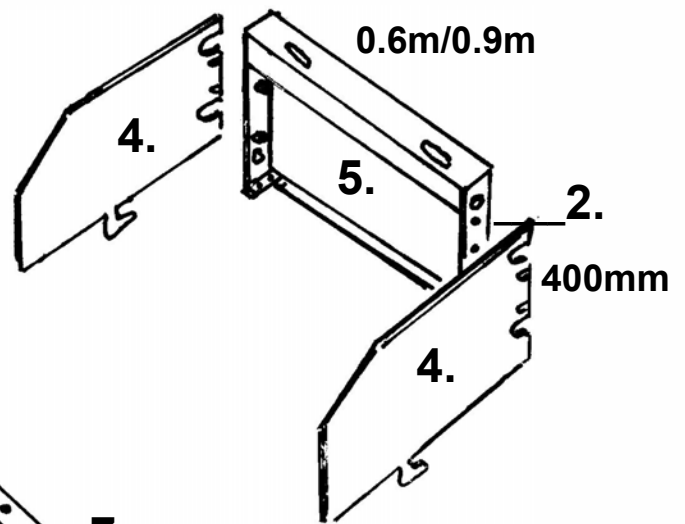

Castors.

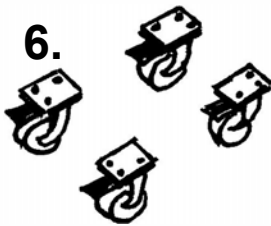

Flouroscent Light.

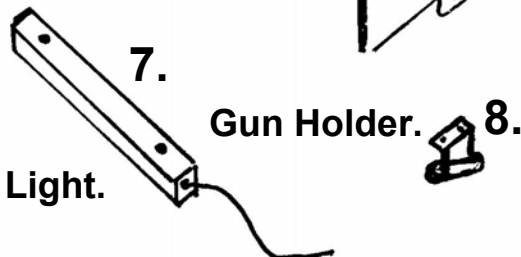

When ordering Spare Parts please specify:

- a. Name and P-number of Your Product.
- b. Number and Text from below.
- c. Quantity of each Spare Part.

1. Quick Release Side Shield/200mm high (1pc.).
2. Hex Socket Cap Bolts M6x16mm for Quick Release (4pcs.)
3. 3a. Back Shield 0.6m wide/200mm high with Hex Socket Cap Bolts 4xM6x16mm and Locking Nuts 4xM6 (1pc.).
3b. Back Shield 0.9m wide/200mm high with Hex Socket Cap Bolts 4xM6x16mm and Locking Nuts 4xM6 (1pc.).
4. Quick Release Side Shield/400mm high (1pc.).
5. 5a. Back Shield 0.6m wide/400mm high with Hex Socket Cap Bolts 4xM6x16mm and Locking Nuts 4xM6 (1Pc.).
5b. Back Shield 0.9m wide/400mm high with Hex Socket Cap Bolts 4xM6x16mm and Locking Nuts 4xM6 (1pc.).
6. Castor 125mm high with Brake. 360 Degree (1pc.).
7. Flouroscent Light for 400mm high Back Shield (1pc.)
8. Gun Holder + 2xM6 Hex Socket Countersunk Bolts (1pc.)



Declaration of conformity

We, J. Plymoth AB, declare under our sole responsibility that the product lines **MF-F9/HEPA, MF-Active Carbon, MF-Eco/F9, MF-Eco/HEPA, MF-Filter-Tables, MF-Eco Filter-Tables, FK-Mesa Backdraft Filter-Tables, MKF Filter-Tables, Labbe, MF-Lab, MF-Eco Lab, CF Central Filters, Mobo-Oil, Denta-Flex, Fica-Flex and VBF-Office** to which this declaration relates is in conformity with Directives 2006/42/EC, 2014/30/EU, 2011/65/EU and Standards EN 60204-1:2006, EN ISO 12100:2010, EN ISO 15012-1:2013, EN 61000-6-2:2005, EN 61000-6-3:2007, EN ISO 20607:2019.

J. Plymoth AB
Traryds Allen 4D
28772 Traryd

87

A handwritten signature in blue ink, appearing to read 'Jenny Nilsson', is written over the printed name and title.

Jenny Nilsson
Verkställande Direktör

2023-01-01