

User Manual



Super-Mesa 1.4m



Super-Mesa 1m.

- Back Draft Extraction Tables 1m/1.4m wide
- Robust industrial design
- Outlet connection/s dia. 199mm outside.
- Frontside damper/dampers.
- Easy to open side panels
- Welding gun holder (Accessory)
- Easy to assemble and install
- Height adjustable legs.
- Spark Trap/Traps (Accessory)

Table of Contents

1.0 General Information

1.1 SafetyNote

1.2 Rangeof Application

1.3 Unit Description

1.4 Installation

1.5 Mounting

2.0 Maintenance

2.1 General Information

2.2 Spare Parts

1.0 General Information

The Super-Mesa Backdraft Tables are designed for creating worker friendly Environments. They can be used for all sorts of work situations where a table and extraction of contaminated air is needed.

The unit shall be connected to a central ducting system which is designed to take care of the exhausted contaminations.

The working height can be adjusted from 820-970mm.

The tables are robustly made of 3mm thick steel plate.

The side shields have hinges and quick release locks.

Super-Mesa is prepared for being equipped with a Flexi FLB Extraction-Arm (1.5m/2m/3m. Accessory) on the top of the backdraft box. You can then concentrate the suction to a spot where it is especially needed or with 2/3m arm reach outside the Super-Mesa Table.

1.1 Safety Note

Always interrupt the current before opening the device.
Equip the Super-Mesa with Spark Trap if it will be used for applications with Sparks.

Follow all regulations regarding Explosion Risks.

1.2 Range of Application

Super-Mesa Backdraft Tables are for extraction of Gas, Fume and Dust from all sorts of work. It has to be connected to an extraction source. The extraction system shall be designed for the actual type of contamination and local laws.

The Super-Mesa units are made for indoor use.

1.3 Unit Description

Super-Mesa. 1m and 1.4m

Plymoth Super-Mesa is a modern Backdraft Table with built in regulating Damper. 1m and 1.4m Models.

Dust, Fume and Gases. Plymoth Super-Mesa is suitable for welding and grinding. It can also be used in many other applications where dust, fume and gases are a problem.

Funnel-shaped Extraction Openings. The extraction is through the backdraft panel. It's vertical funnel-shaped extraction openings guarantee maximum efficiency.

Unique regulating Damper. Plymoth Super-Mesa is as standard equipped with a regulating damper which makes it possible to adjust the width of the vertical openings of the backdraft panel. If an extraction arm is fitted you can easily adjust the total air volume between the arm and the backdraft panel with a handle on the front side.

Extraction Arm. For heavy welding the Super-Mesa can be equipped with a Flexi FLB 1.5m extraction arm. If it is needed to reach outside the table you can mount a 2m or a 3m Flexi FLB extraction arm.

Good Grounding. The table surface is just oiled to give a good ground when it is used for welding.

Strongly designed. Plymoth Super-Mesa is designed of 2 and 3mm steel-sheet. The table height can be adjusted from 800-950mm. The side panels can be opened for long objects. Suitable air volume for 1m table is 1300-1700m³/h and for 1.4m table 1500-2200m³/h. It shall be connected with an external fan and extraction system. Connection diameter is 199mm outside.



	Art.Nr.
Super-Mesa 1m with side panels. 1mx1m (LxW).	P-774
Super-Mesa 1.4m with side panels. 1.4mx1m (LxW).	P-775
Spark Trap for Super-Mesa 1m. 1Pc.	P-778
Spark Trap for Super-Mesa 1.4m. 2 Pcs.	P-779
Flexi FLB Extraction Arm 1.5m. Diameter 160mm.	P-069

*The Super-Mesa in the picture is extra equipped with a 1.5m Flexi FLB extraction arm.

Measures: Super-Mesa 1 m/1.4m (mm.).
 The measures on Super-Mesa 1m are the same as on 1.4m if not written out.

Super-Mesa 1m

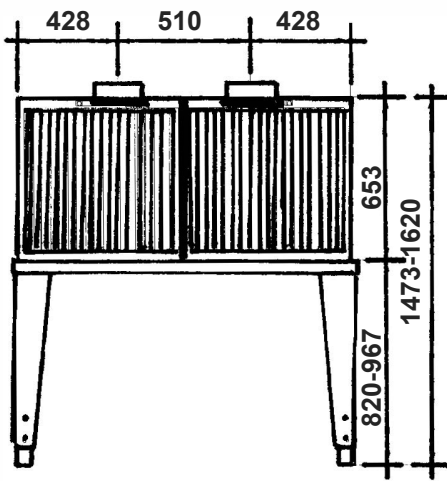
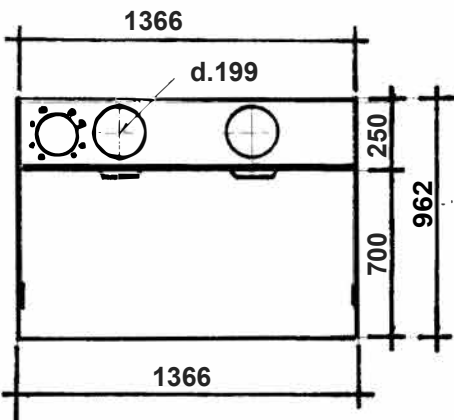
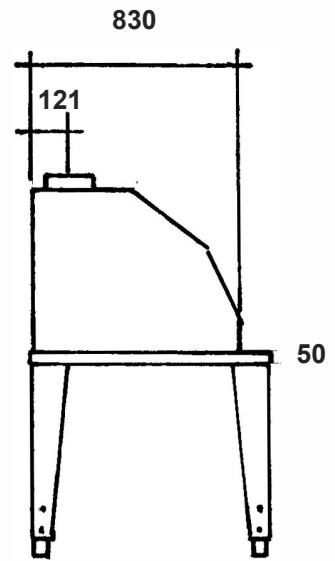
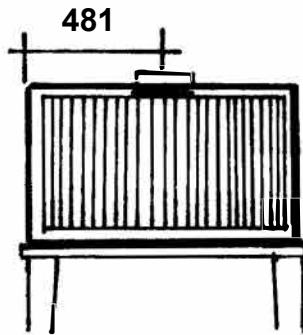
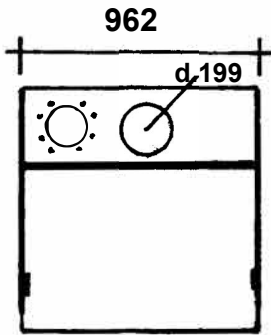

Super-Mesa 1.4m

Extraction-Arm (Accessory).

Seen from the front side, on the top to the left is a hole prepared for mounting of an Extraction-Arm. It has 8xM8 Pop-Nut Threads. It is covered with a bolted steel lid.

Technical data

	Super-Mesa 1m	Super-Mesa 1.4m
Recommended Airflow:	1500m ³ /h	2000m ³ /h
Pressure Drop:	170Pa	250Pa
Pressure Drop with Spark Trap:	230Pa	350Pa
Max. Load:	100kg	100kg
Weight:	100kg	140kg
Outlet on top of unit outside:	199mm	2x199mm
Prepared for 1xExtraction-Arm 1.5m, 2m or 3m on top of unit.		

Accessories

Spark Trap

Metal mesh filter that reduces the risk of extracting hot sparks which can cause fire. For mounting in the back panel.

Flexi FLB Extraction-Arm. 1.5m, 2m or 3m for mounting in a prepared hole. This hole is covered with a bolted steel plate. The bolts shall be used for the FLB Extraction-Arm.

1.4 Installation

After the mounting of the Super-Mesa it shall be transported to the place where it shall be installed and connected to an extraction system.

The extraction system can be of the following types:

1. Ducting to a Fan and sent out of the building.
2. Connection to a central ducting system with a fan in the end and out of the building.
3. Like 2. above but with a Heat Exchanger before it is sent out of the building.
4. Connection to a filter unit and sent out of the building or if allowed returned to the room. Which to choose depends on Exhausted Contaminations, Filter Unit and Local Laws.
5. Connection to a central ducting system with a Filter Unit and sent out of the building or returned to the room. Which depends on Exhausted Contaminations, Filter Unit and Local Laws.
6. 4 and 5 above can be equipped with Heat Exchanger if sent out of the building.

It is advisable to use dia. 200mm ducting from the Super-Mesa Unit. It fits directly to the outlet/outlets and keeps down the pressure drop. When the unit is connected to the extraction system you shall bolt it to the floor. There are prepared holes in the feet.

Flexi FLB Extraction Arm 1.5/2m or 3m (Accessory) can be mounted on the prepared place on the top of the Super-Mesa at any time. For complete instruction see User Manual for Flexi Table Extraction Arms.

1.5 Mounting.

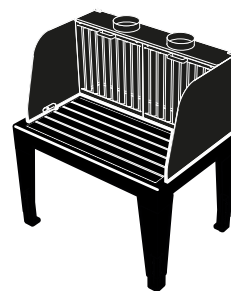
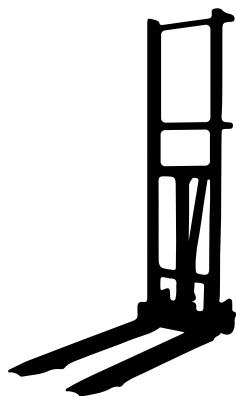
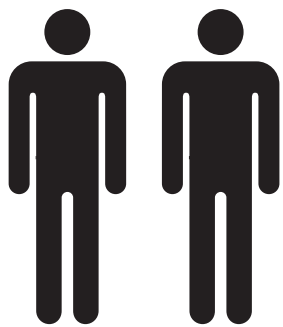

100kg/140kg

The Super-Mesa 1m is mounted in the same way as 1.4m.

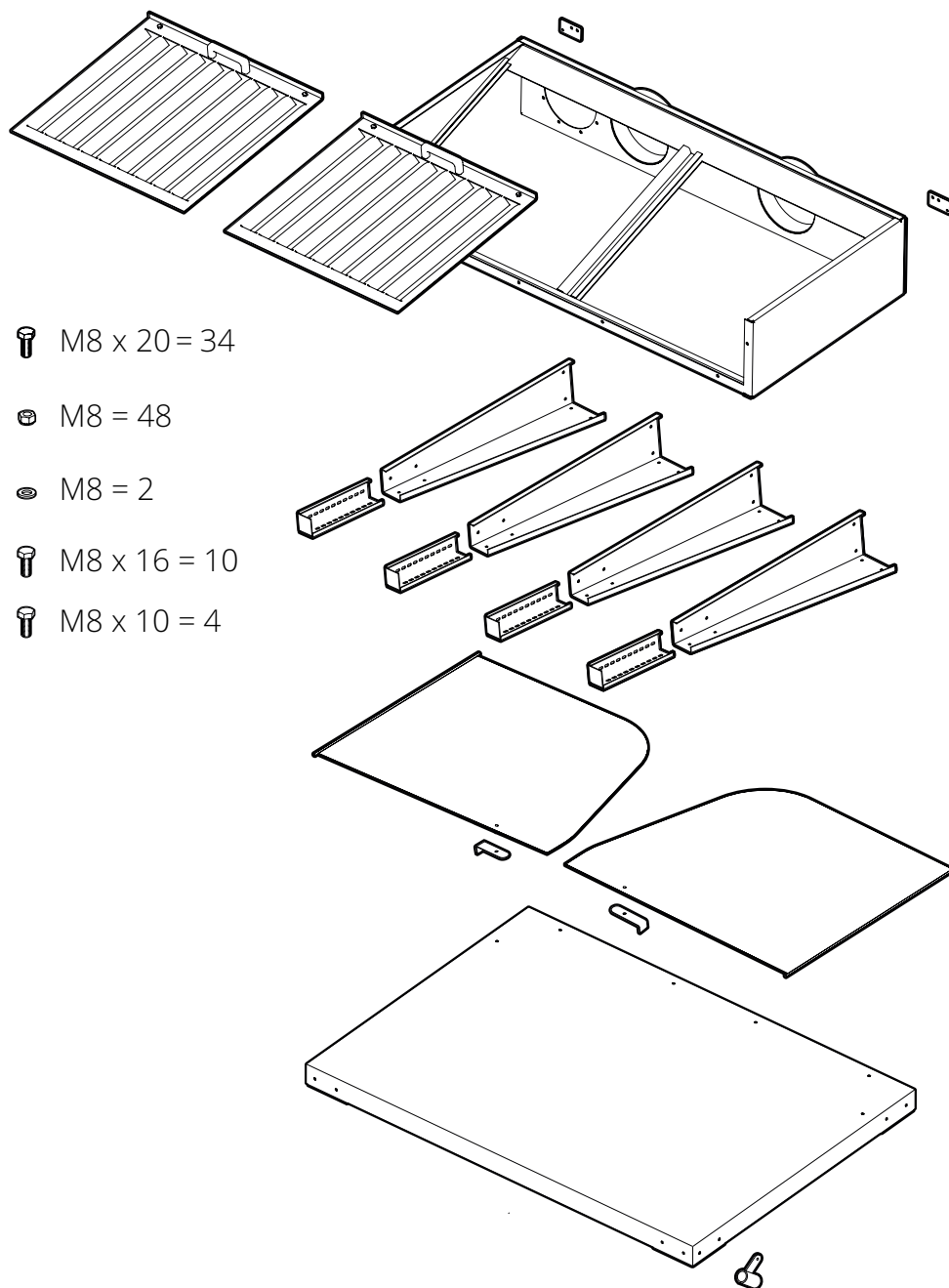

Recommended Mounting Steps.

1

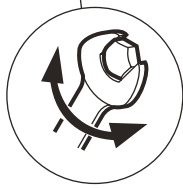
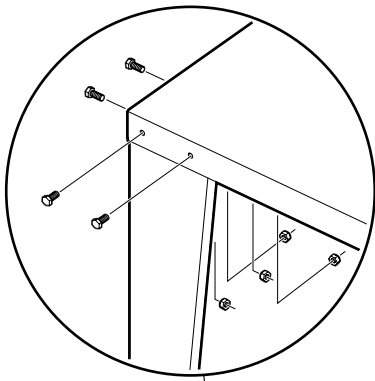

13 mm
M8x20 x 12

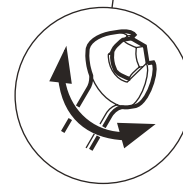
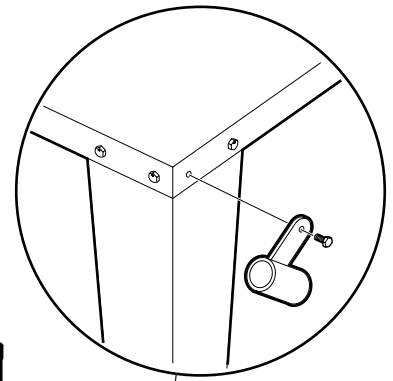
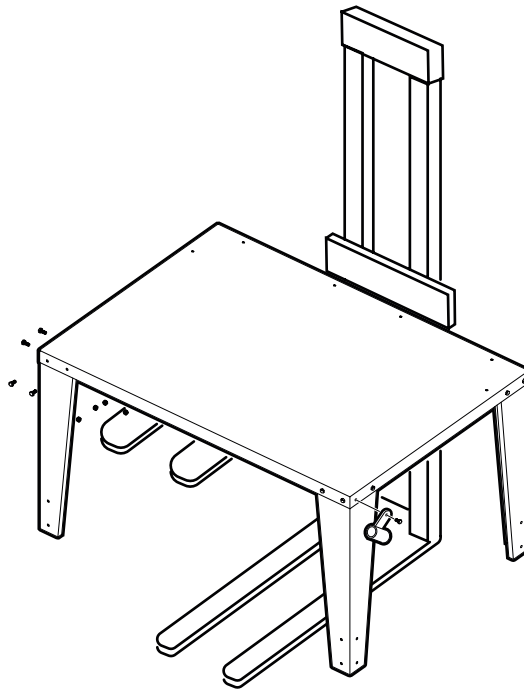

13 mm
M8x20 x 12

2

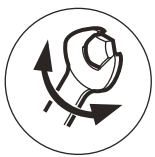

13 mm
M8x20 x 16

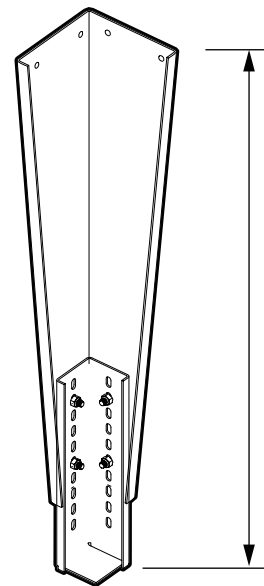
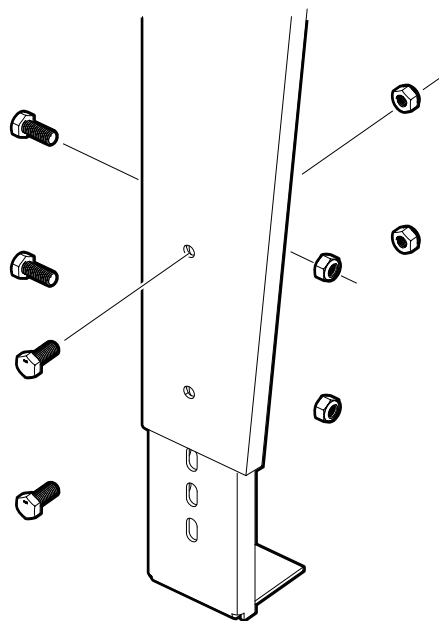

80 - 95 cm

3

Prepared for Extraction-Arm.

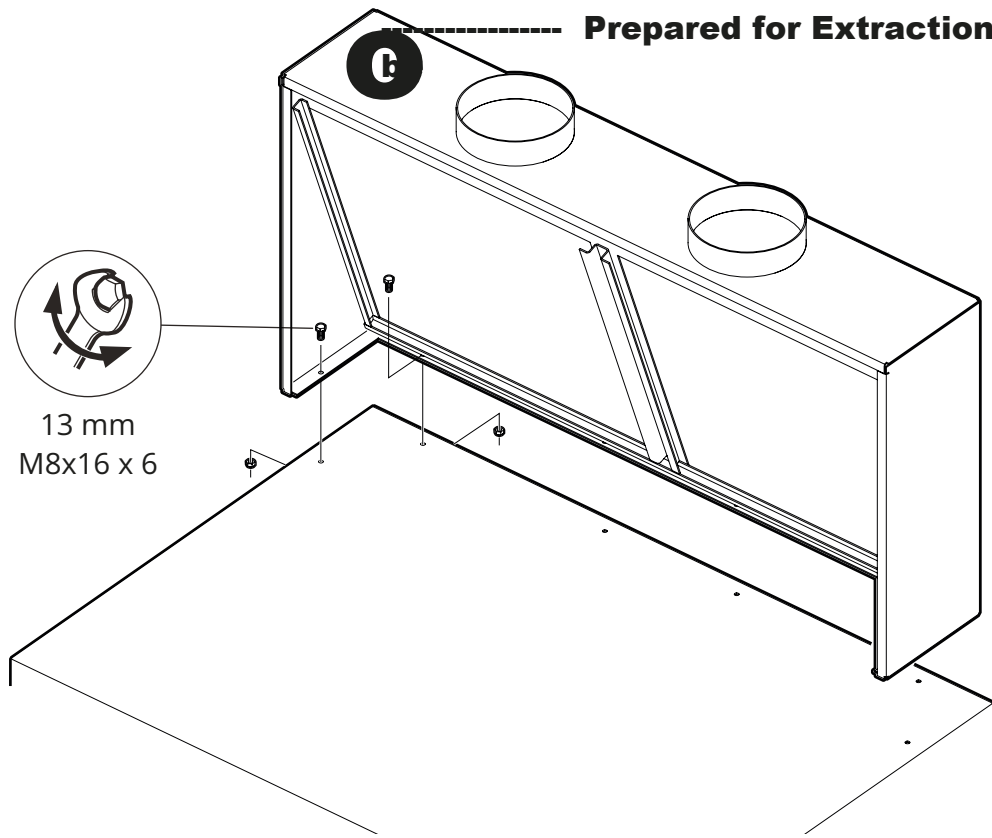

4

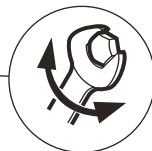

13 mm
M8x16 x 4

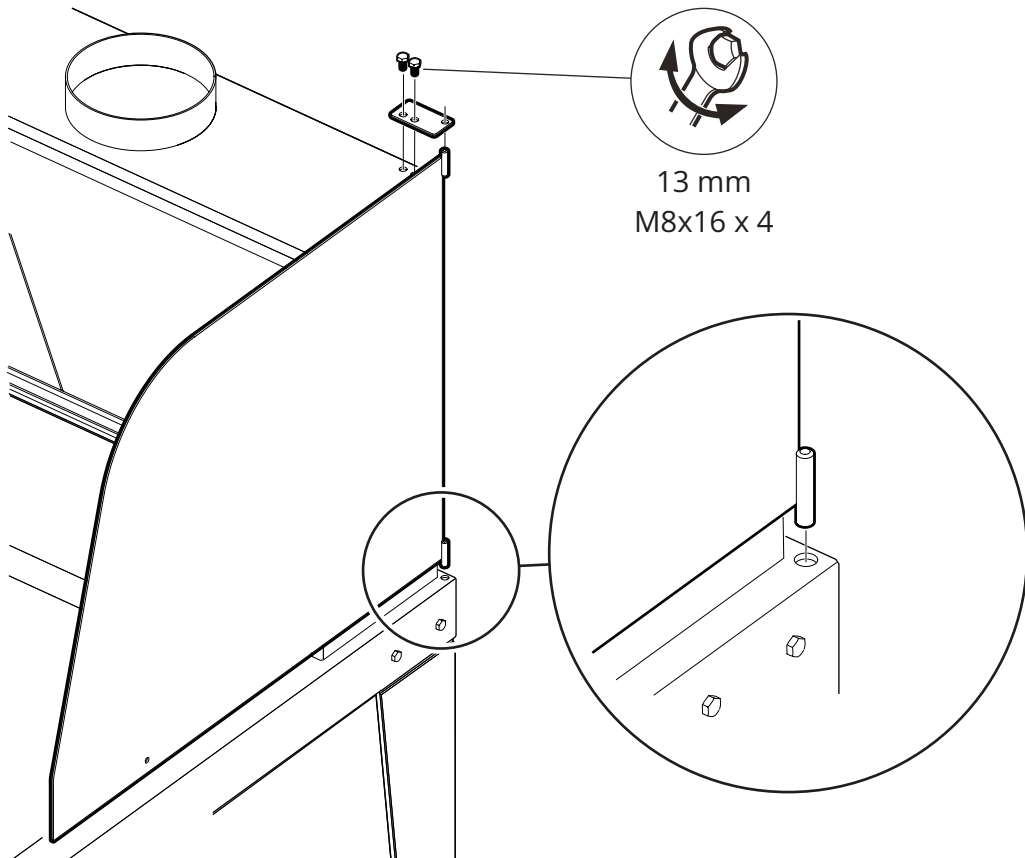

5

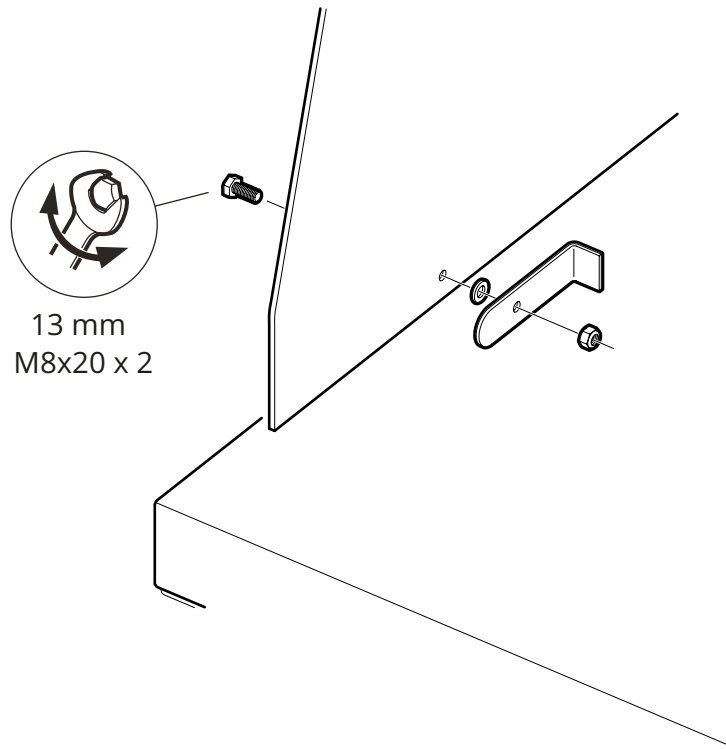

6

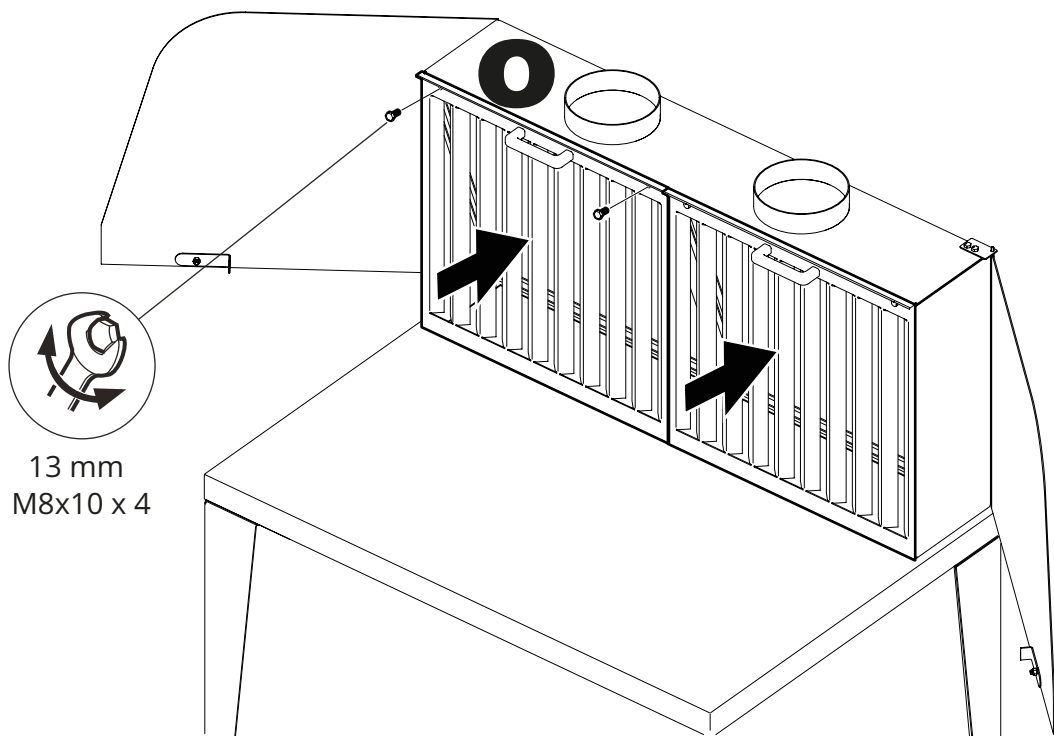

Spark Trap (Accessory).

Has to be mounted before mounting step number 6 above.

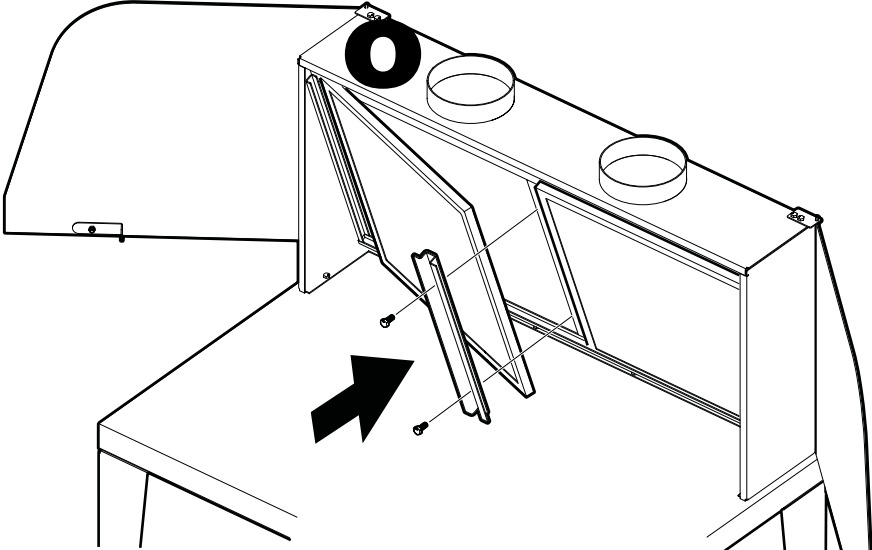
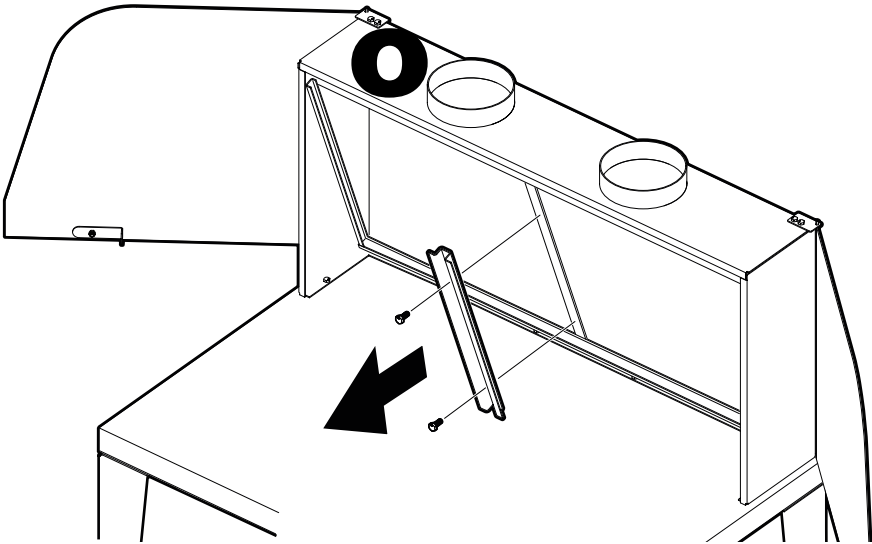
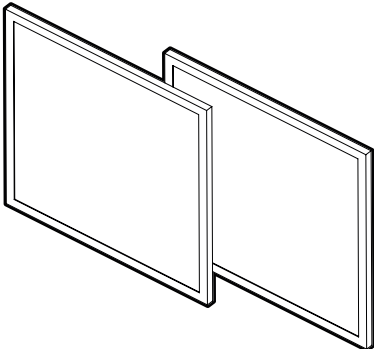

Flexi FLB Extraction-Arm.

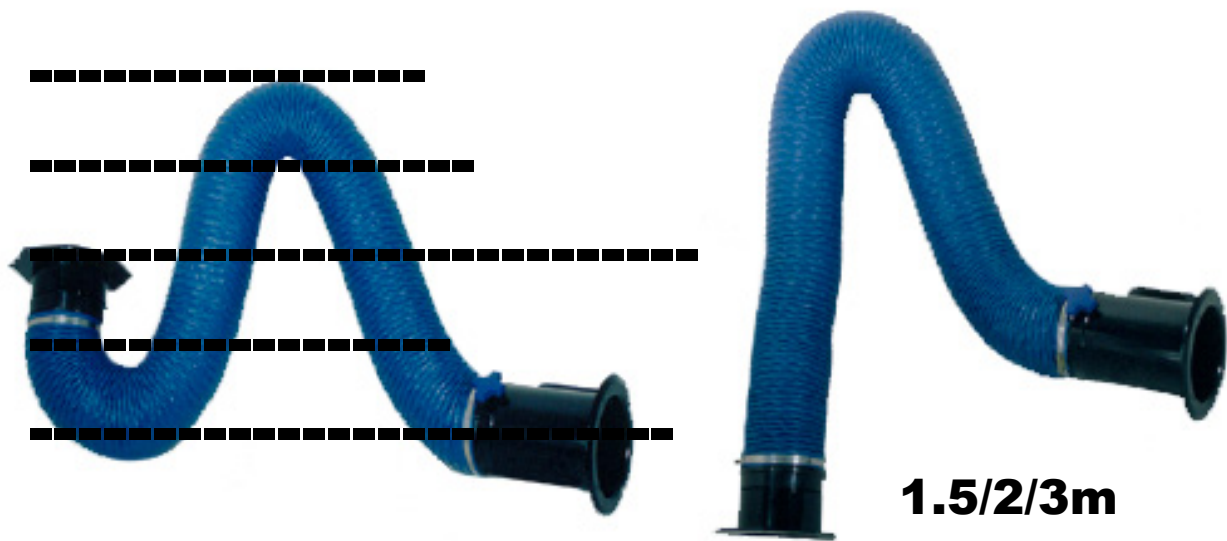

General Information.

The Flexi FLB Table/Mobile-Filter/Super-Mesa/Maxi-Mesa Extraction-Arms are designed to extract dust, fume and gases. They have a swivel which allows the Arm to be rotated 360 degrees. The flame-proof flexible hose, with covered steelspiral, has a parallelogram system inside to balance the hose and hood. This makes the Hood extremely easy to move to a new position and will stay there.

The Flexi steel hood is black painted and can be turned 90 degrees in all directions. It can easily be positioned at any point within the working area.

The Flexi FLB can be mounted on Super-Mesa and Maxi-Mesa Extraction Tables. The top of the units has a prepared mounting place with 8xM8 threads. You can easily mount the arm even after the Super/Maxi-Mesa is in use. There are 1.5m, 2m and 3m models with dia.160mm hose. With a 3m FLB Extraction-Arm the unit is not just a Clean Air table area but can also cover a exhaust contaminated air in a 3x3m work both.

Max allowed vacuum is 1600Pa.

Max temperature of the exhausted air is 70 Degrees Celsius.

Recomended airflow for d.160mm Arms is 600-1000m³/h.

2.0 Maintenance

2.1 General Information.

The Super-Mesa Extraction Tables are robust and normally don't need much maintenance. However the following should be checked at least 2 times a year.

- 1. Check that the leg bolts are tight.**
- 2. Check that the Horizontal Damper is working smoothly. If not demount and clean . At the same time clean the area behind and the Spark Trap (Accessory).**
- 3. If the Super-Mesa is equipped with an Extraction Arm (Accessory) check the hose. Small holes are no problem. If the Arm doesn't stay in position loosen the hose and tighten the friction joints.**

2.2 Spare Parts Super-Mesa 1m and 1.4m

When ordering spare parts please specify:

1. Name and P-number of your product.
2. Number/numbers and text from below.
3. Quantity of each number/numbers.

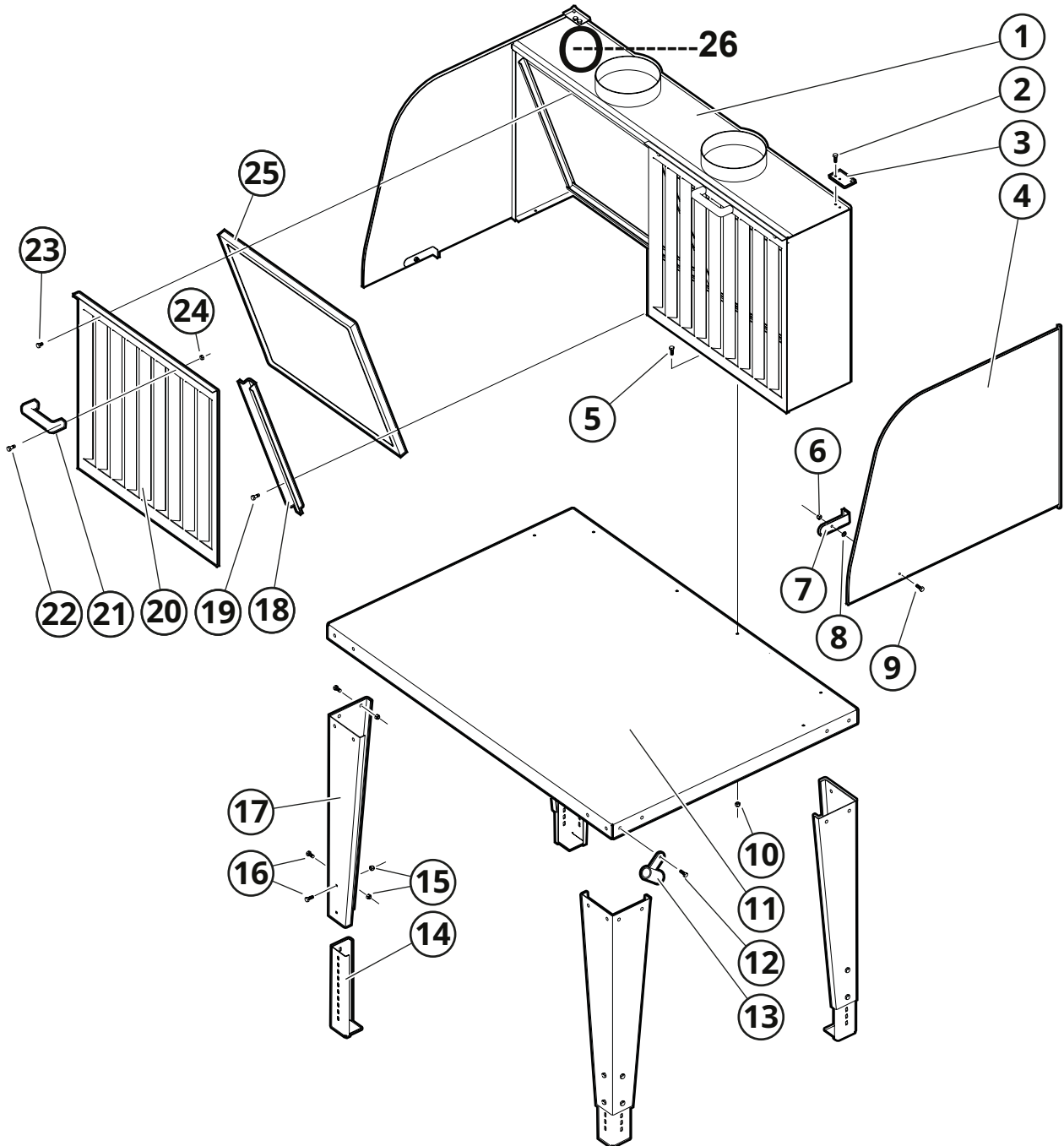

1.Backdraft Box 2.Bolt 3."Ear" for Side Panels 4.Side Panel 5.Bolt for Backdraft Box
 6/7/8/9 Quick Lock for Side Panel 10.Nut for Backdraft Box 11.Table Top
 12/13.Welding Pistol Holder (Accessory) 14.Adjustable Leg 15/16.Bolt and Nut
 17.Leg 18/19.Spark-Trap-Holder and Bolts 20/23.Horizontal Damper and Bolts
 21/22/24.Handle with Bolt/Nut 25.Spark Trap (Accessory) 26.Cover Plate over hole
 with 8xM8 Pop-Nut threads for Extraction-Arm (Arm is Accessory).

Spare Parts: Flexi FLB Extraction-Arm, 1.5m/2m/3m/dia.160mm for Super-Mesa

SPARE PARTS

ERSATZTEILE

PIÈCES DE RECHANGE

PIEZAS DE REPUESTO

1.5m=P-069
2m=P-168
3m=P-169

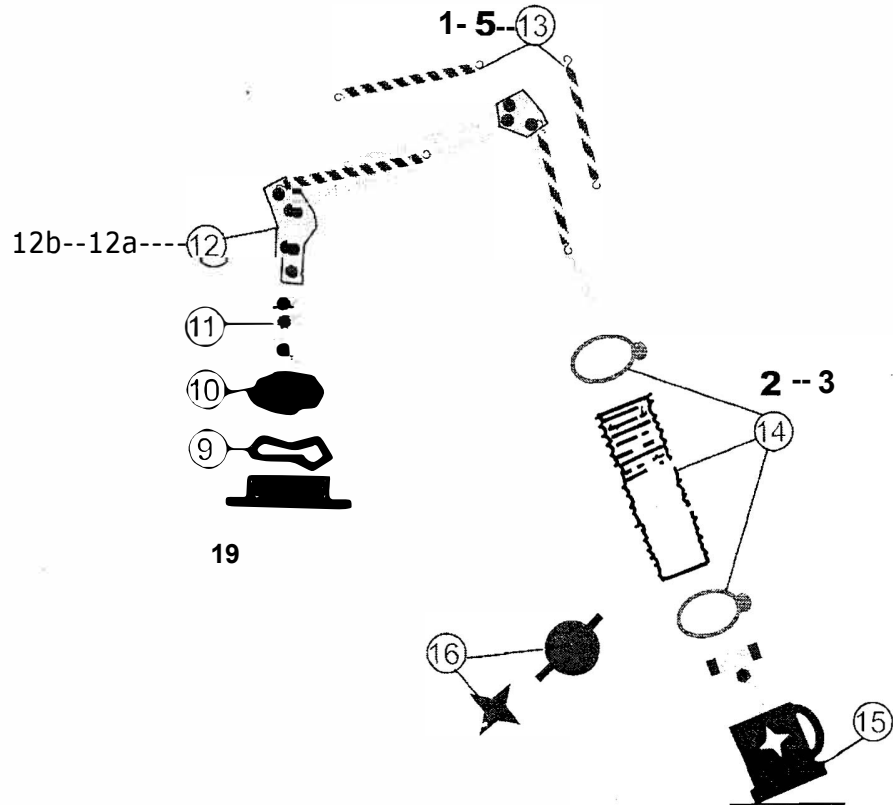

ENGLISH ORDER INSTRUCTION

When ordering spare parts always state:
-Name of the Product.

-Detail no. of the spare part and the name as per list below.
-Quantity of the parts required

DEUTCH BESTELLANLEITUNG

Bei der Bestellung von Ersatzteilen immer angeben:
- Ersatzteilnummer und Beschreibung (s. Liste unten).
- Anzahl erforderlicher Ersatzteile.

FRANCAIS INSTRUCTIONS DE COMMANDE

Lors de la commande de pièces de rechange, toujours spécifier:
- Numéro de détail et dénomination (voir liste).
- Quantités des pièces requises.

ESPAÑOL INSTRUCCIONES DE PEDIDO

Cuando pida repuestos especifique siempre:
- N° de pieza del repuesto (en la lista).
- Cantidad de repuestos requeridos.

- | | |
|-----|---------------------------|
| 1. | Spring Set 1.5m Arm |
| 2. | Hose+Hose Clamps 1.5m Arm |
| 3. | Hose+Hose Clamps 2m Arm |
| 5. | Spring Set 2m Arm |
| 9. | Rubber kollar |
| 10. | Hose ring of Plastic |
| 11. | Shaft |
| 12. | Inside Arm 1.5 m complete |
| 12a | inside Arm 2m complete |
| 12b | Inside Arm 3m complete |
| 13. | Spring set 3m Arm |
| 14. | Hose+Clamps 3m Arm |
| 15. | Hood, complete |
| 16. | Damper set |
| 19 | Arm Holder |



Declaration of conformity

We, J. Plymoth AB, declare under our sole responsibility that the product lines **Flexa, Chemikus, Flexi, Super-Max, Super-Vac, Super-Mesa and Maxi-Mesa** to which this declaration relates is in conformity with Directives 2006/42/EC and Standards EN ISO 12100:2010 and EN ISO20607;2019.

J. Plymoth AB
Traryds Allen 4D
28772 Traryd

Jenny Nilsson
Verkställande Direktör

2023-01-01