

# Technical Data



## **CF-LAB/Active Carbon (30Ltr.) Central Extractor-Filter.**

- **Extractor-Filter for 1-2 dia.160mm or 4-8 dia.75/100mm Extraction-Arms.**
- **Perfect for Cleaning/Degreasing, Conservation, Gluing/Bonding, Moulding, Screenprinting and similar work situations.**
- **Filter Cartridge, with Prefilter-Fleece and 30Ltr. Active Carbon.**
- **The Filter Media can be changed to F9 Filter Cartridge or HEPA H13 Filterbox when/if needed.**
- **Initial Extraction volume 1400-1800m<sup>3</sup>/h.**
- **Clean Air Outlet at the Bottom of the Unit.**
- **Single Phase or Three Phase models.**

## General Information.

A CF-LAB/Active Carbon Extractor-Filter System is an easy way to create a clean environment with clean air. You get 1000m<sup>3</sup>/h through the Hood of one Extraction-Arm or 2x700m<sup>3</sup>/h through two. It is then possible to catch the contaminations from a larger area without moving the Hood.

Laboratories or areas where you just need to exhaust from a small spot at a time.

A CF-LAB/Active Carbon Extractor-Filter System is simple to install. Mount the Extraction-Arm/Arms on the wall. Mount dia.160mm or dia.75/100mm ducting upwards to a dia.200mm Horizontal Ducting. Extend the dia.200mm Horizontal Duct to a place where you can mount the CF-LAB Extractor-Filter. Go down with a dia.200mm Duct to the Unit. Bolt the CF-LAB to the floor and just plug it into an electric socket (1-phase models). 3-phase models have to be connected by a certified electrician.

CF-LAB/Active Carbon Extractor-Filters can be used for all sorts of work where extraction and filtration of Gas and Odours is needed. Perfect for Cleaning/Degreasing, Conservation, Gluing/Bonding, Moulding, Screenprinting, Mixing, Taking Samples, Experiments, Examinations and so on.

The Door has 4 expander locks to make it easy to open and lock. 4 locks make sure that the door is tight.

To replace the Active Carbon Filter Cartridge you open the door and pull the Filter Cartridge out and replace it with a new. Seal Downwards!

The Unit can be equipped with a F9 or HEPA H13 Filter instead of the Carbon Filter if the work situation will change.

## Safety Note.

**Always disconnect the electricity supply before opening the CF-Unit.**

Don't exhaust Sparks or Poisenous Dust.

Use adequate safety clothing when replacing dirty filters.

Dispose of used Filters according to local laws and regulations.

## Range of Application.

The CF-LAB/Active Carbon Extractor Filter is designed for work situations where Gas and Odours is a problem. It is for indoor use. The unit is suitable for Gas and Odours from Cleaning/Degreasing, Conservation, Gluing/Bonding, Screenprinting, Mixing, Taking Samples, Experiments, Examinations etc.

The filtered air can be recirculated into the room as long it is not against local Laws and Regulations.

# Unit Description

## CF-LAB/Active Carbon. Central Extractor Filter.

### Active Carbon 30 Ltr.

CF-LAB/Active Carbon Central Extractor Filter is equipped with a 30Ltr Active Carbon Filter Cartridge with a Pre-Filter Fleece on the outside. It is suitable for filtering gases and odours.

### Application Examples.

1. Cleaning / Degreasing
2. Conservation
3. Gluing / Bonding
4. Moulding
5. Screen Printing
6. Mixing, Measuring, Taking Samples, Examinations etc.

### Replacement Filter Cartridge.

It is time to put in a Replacement Filter when the extraction is not satisfactory or the odours come back. It is easy to change the Filter Cartridge and will just take a few minutes.

### Capacity.

4-8 Flexa/Chemikus Extraction Arms (d. 75/100mm) can be connected to a CF-LAB/Active Carbon Extractor Filter or 1-2 Flexi Extraction-Arms (d.160mm/max.2m).

### Installation.

The inlet diameter is 199mm. Use d.200mm Vertical/Horizontal ducting from the CF-LAB and go down with dia.75/100mm ducts to the Flexa/Chemikus Extraction Arms or dia.160mm duct to Flexi dia.160mm Extraction-Arm/Arms.

**Ask our specialists for further advice.**



	Art. No.
CF-LAB/Active Carbon. ~1/1.1kW/220V/50Hz. 30Ltr. Act.Carb. Inlet 199mm. Legs (0.5m).	P-1012
CF-LAB/Active Carbon. ~3/1.1kW/400V/50Hz. 30Ltr. Act.Carb. Inlet 199mm. Legs (0.5m)	P-1013
Replacement Active Carbon Cartridge 30Ltr. For MF, WF, CF, MF-Filter Tables (High).	P-962

## CF-LAB/Active Carbon Extractor-Filter.

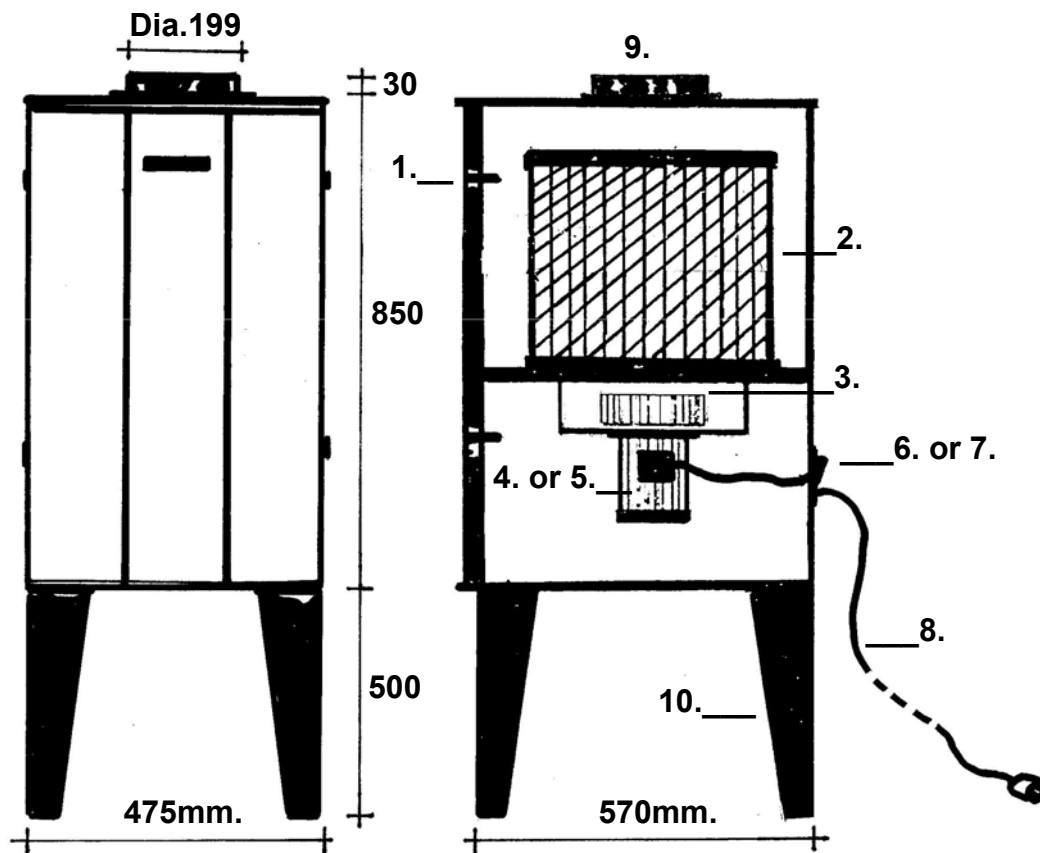

1. Door with 4xExenter Locks.
2. Active Carbon Filter Cartridge 30Ltr. with Prefilter Fleece.
3. Impellar.
4. Electric Motor 1-phase/1.1kw/220V/50Hz.
5. Electric Motor 3-phase/1.1kw/400V/50-60Hz.
6. On/Off Switch 1-phase with overload protection.
7. Connection Box for 3-phase versions.
8. Cable and Plug for 1-phase versions.
9. Inlet Flange outside dia.199mm.
10. Legs 500mm.

## Applications: CF-LAB/Active Carbon Extractor-Filter.

### Vapour from solvents (VOC).

Nearly all solvents are Volatile Organic Compounds or liquids. They are used in a many every day applications, such as component cleaning, degreasing, and to dissolve products that are not able to be dissolved in water. They also form the drying agent in products such as adhesives, paints, and varnishes.

Vapours from these solvents have a narcotic effect that can cause tiredness, dizziness and intoxication. Vapour and gases from solvents can also enter your body by the respiratory system and then spread to the brain and liver. The vapours from solvents are also irritating for your eyes and respiratory system.

By using a CF-LAB/Active Carbon Extractor-Filter you get an effective extraction solution combined with an efficient filter system. You will reduce or eliminate the risk of working with airborne Gases and Odors.

Type of application	Hazard substances
Soldering (Electronic)	Resin, Lead, Terpene, Limonene, Borneol, Isosyanates
Solder Pot	Resin, Lead, Terpene
Gluing / Bonding	VOCs1, Methylmetacrylate (MMA), Toluene, Ethyl-2-cyanoacrylate, Tetrahydrofuran, Cyklohexanone
Screen printing	Methyl ethyl ketone (MEK), Toluene
Cleaning / Degreasing	Acetone, Toluene, MEK, VOCs1
Laser cutting	Dust, metal particulate, odour
Moulding	Epoxi, Styrene
Conservation	VOCs1
Precision TIG welding	Welding fume, Gases, Ozone
Stained Glass working	Lead fume, VOCs1
Botany research	VOCs1
Sculpturing	VOCs1, silica dust, sealants

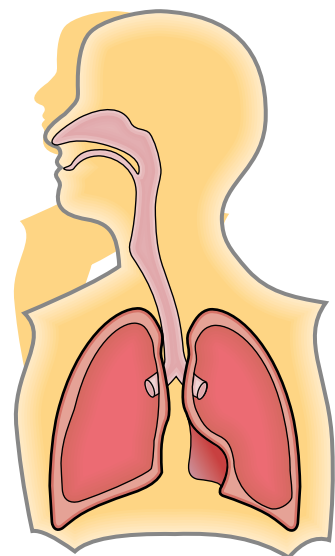

## Installation.

**2x160mm Extraction-Arms max.2m length (Flexi or Super-Max).**

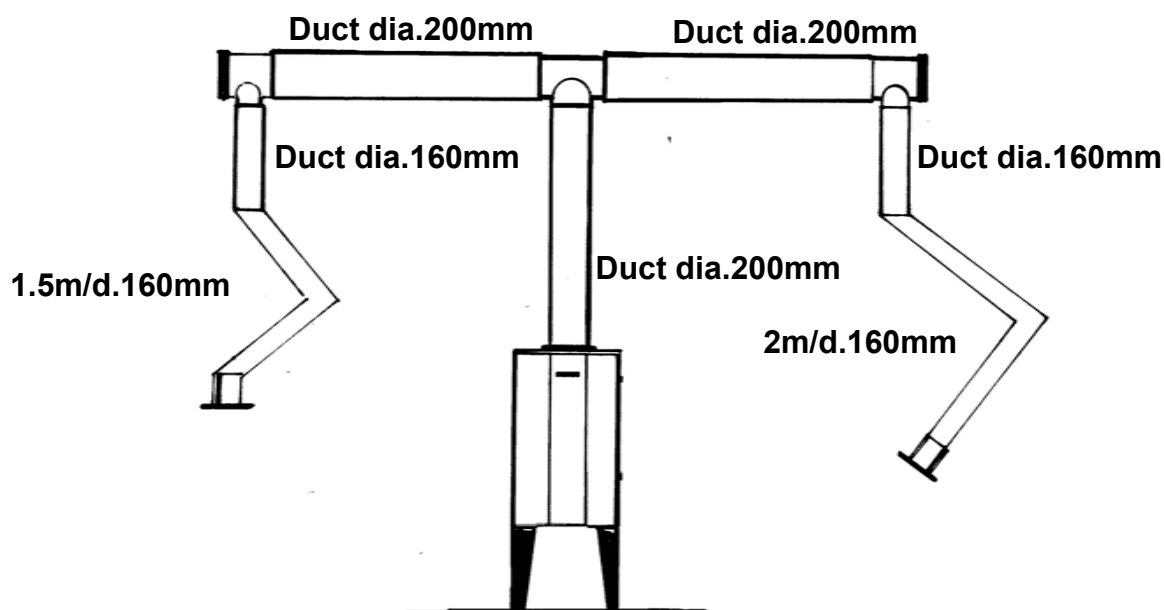

**4-8 dia.75 or dia.100mm Extraction-Arms (Flexa or Chemikus).**



**From the CF Unit Vertical and Horizontal Ducting dia.200mm.  
From Horizontal Ducting to Extraction-Arm dia.75mm or 100mm.**



### Declaration of conformity

We, J. Plymoth AB, declare under our sole responsibility that the product lines **MF-F9/HEPA, MF-Active Carbon, MF-Eco/F9, MF-Eco/HEPA, MF-Filter-Tables, MF-Eco Filter-Tables, FK-Mesa Backdraft Filter-Tables, MKF Filter-Tables, Labbe, MF-Lab, MF-Eco Lab, CF Central Filters, Mobo-Oil, Denta-Flex, Fica-Flex and VBF-Office** to which this declaration relates is in conformity with Directives 2006/42/EC, 2014/30/EU, 2011/65/EU and Standards EN 60204-1:2006, EN ISO 12100:2010, EN ISO 15012-1:2013, EN 61000-6-2:2005, EN 61000-6-3:2007, EN ISO 20607:2019.

J. Plymoth AB  
Traryds Allen 4D  
28772 Traryd

87

A handwritten signature in blue ink, appearing to read 'Jenny Nilsson', is written over the printed name and title. The signature is fluid and cursive.

Jenny Nilsson  
Verkställande Direktör

2023-01-01