

# User Manual



## **CF Central Extractor-Filter. F9 or HEPA H13 Filter.**

- **Extractor-Filter for 1-2 dia.160mm or 4-8 dia. 75/100mm Extraction-Arms.**
- **Models with F9 Filter Cartridge (12m<sup>2</sup>) or HEPA H13 Filter Box (9m<sup>2</sup>).**
- **F9 Models Suitable for filtration of light welding fume and light dust.**
- **HEPA H13 Models for light Stainless Steel welding and Fine Dust.**
- **Can be changed from F9 Filter to HEPA H13 Filter if needed.**
- **Initial Extraction volume 1400-1800m<sup>3</sup>/h.**
- **Clean Air Outlet at the Bottom of the Unit.**
- **Single Phase or Three Phase models.**

# **Table of Contents**

## **1.0 General Information**

### **1.1 Safety Note**

### **1.2 Range of Application**

### **1.3 Unite Description**

### **1.4 Installation**

### **1.5 Change of Filter**

## **2.0 Maintenance**

### **2.1 General Information**

### **2.2 Spare Parts**

## **1.0 General Information.**

A CF Extractor-Filter and 1-2 dia.160mm Extraction-Arms is an easy and efficient way to create a work place with clean air when you have light welding or light dust.

For Soldering you can connect 4-8 dia.75mm or 100mm Extraction-Arms.

A CF Extractor-Filter System is simple to install. Mount the Extraction-Arm/ Arms on the wall. Mount dia.160mm or dia.75/100mm ducting upwards to a dia.200mm Horizontal Ducting. Mount a dia.200mm Horizontal Ducting to a place as close as possible and place the CF Extractor-Filter there. Bolt the unit to the floor and just plug it into an electric socket (single phase models) or let a certified electrician install it.

CF Extractor-Filters can be used for all sort of work where extraction and filtration of Fume and Light Dust is needed. Perfect for light welding, soldering and grinding in for example shoos.

The models with HEPA H13/W3 Filter Box are suitable for light stainless steel welding and fine dust. They have an Alu-Mesh Prefilter (washable).

The Door has 4 expander locks to make it easy to open and lock. 4 locks make sure that the door is tight.

To replace the F9 Filter Cartridge you open the door and pull it out and replace it with a new.

To replace the HEPA H13 Filter Box you open the door and just pull the box out. Test if the extraction will be good enough if you wash the prefilter in the top of the HEPA Filter Box. If the extraction is still not good enough you have to replace the HEPA Filter Box.

### **1.1 Safety Note.**

**Always disconnect the electricity supply before opening the CF-Unit.**

Don't exhaust Sparks or Poisenous Dust.

Use adequate safety clothing when replacing dirty filters.

Dispose of used Filters according to local laws and regulations.

### **1.2 Range of Application.**

The CF Extractor Filter is designed for work situations where smaller amounts of fume and dust is generated. The F9 model has a filtration efficiency of 99% and the HEPA H13 OF 99.95%. The filtered air can be recirculated into the the room as long it is not against local laws and regulations.

## 1.3 Unit Description.

### CF-F9 and CF-HEPA H13 are complete Units with Fan and Filter.

Suitable for 1-2 Flexi Extraction-Arms d.160mm or 4-8 Flexa/Chemikus Extraction-Arms dia.75mm or 100mm.

#### CF-F9. Light Welding/Soldering Fume and light Dust.

CF-F9 is made for light welding/soldering fume and light dust. It is equipped with a 12m<sup>2</sup> F9 Filter Cartridge and a built in Fan with aluminium impeller. The legs are 0.5m. The air volume at the diameter 199mm inlet is ca.1800m<sup>3</sup>/h.

#### CF-HEPA H13/W3. Light Stainless Steel welding.

CF-HEPA H13/W3 is equipped with a HEPA H13/W3 (9m<sup>2</sup>) Filter Box with an Alu-Mesh Prefilter (washable). The Unit can be used for light stainless steel welding/soldering. Airvolume ca.1400m<sup>3</sup>/h.

#### Replacement Filter Cartridge.

It is time to put in a Replacement Filter when the extraction doesn't catch the smoke or dust in a satisfactoring way. It just takes a few minutes to change.

#### Capacity.

4-8 Flexa/Chemikus Extraction Arms (d. 75-100mm) can be connected to a CF Central Extractor Filter or 1-2 Flexi Extraction Arms (d. 160mm).

**Installation.**The inlet diameter is 199mm. Use dia.200mm Vertical/Horizontal ducting from the CF and go down with 75/100mm ducts to the Flexa/Chemikus Extraction Arms.

For d.160mm Flexi Extraction-Arms the vertical duct to the Arms shall be dia.160mm.



	Art. No.
CF-F9. ~1/1.1kW/220V/50Hz. F9 Filter(12m <sup>2</sup> ). Inlet 200mm. 4 Legs (0.5m).	P-963
CF-F9. ~3/1.1kW/400V/50Hz. F9 Filter(12m <sup>2</sup> ). Inlet 200mm. 4 Legs (0.5m)	P-964
CF-HEPA H13/W3. ~1/1.1Kw/220V/50Hz. H13/W3 Filter(9m <sup>2</sup> ). Inlet 200mm. 4 Legs (0.5m)	P-965
CF-HEPA H13/W3. ~3/1.1Kw/400V/50Hz. H13/W3 Filter(9m <sup>2</sup> ). Inlet 200mm. 4 Legs (0.5m)	P-966
F9 Replacement Filter Cartridge 12m <sup>2</sup> . For MF, CF-F9, MF-Filter Tables/High.	P-160
HEPA H13/W3 Filter Box 9m <sup>2</sup> . For MF, CF-F9, CF-HEPA (400x505x200mm).	P-577

## CF Extractor-Filters (F9 and HEPA H13).

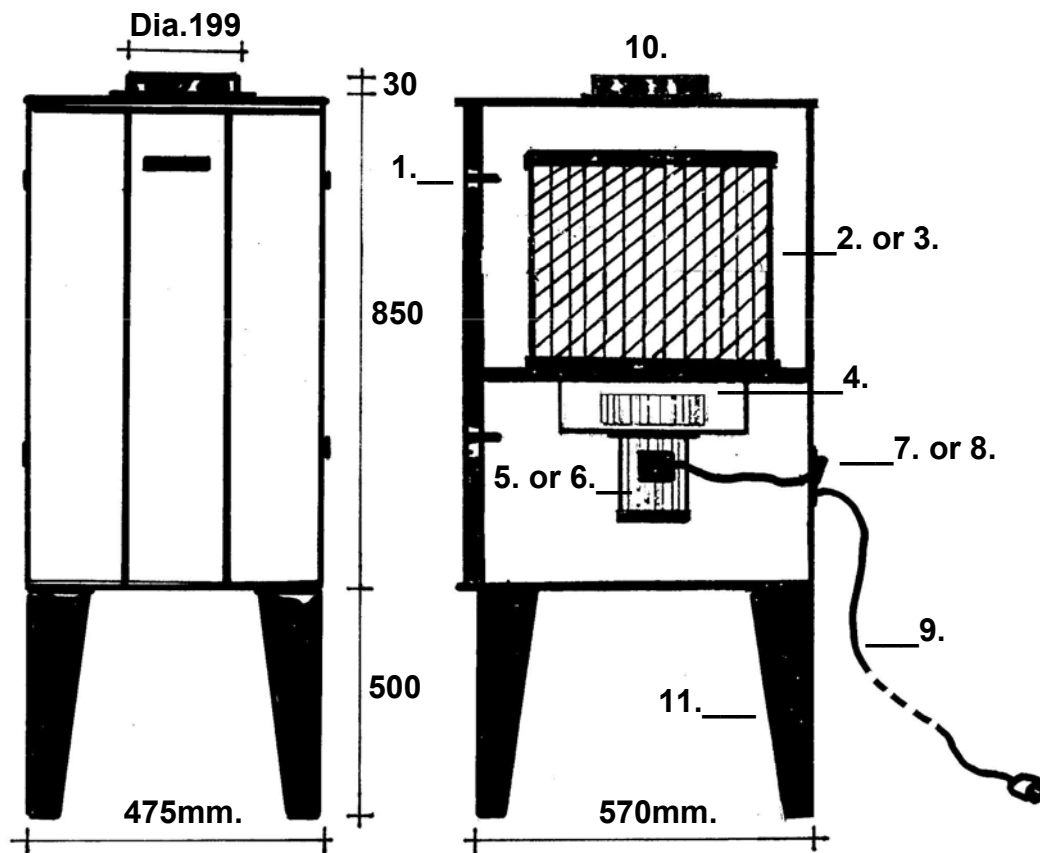

1. Door with 4xExenter Locks.
2. F9 Filter Cartridge 12m<sup>2</sup>.
3. HEPA H13 Filter Box 9m<sup>2</sup>. with Alu-Mesh Prefilter.
4. Impellar.
5. Electric Motor 1-phase/1.1kw/220V/50Hz.
6. Electric Motor 3-phase/1.1kw/400V/50-60Hz.
7. On/Off Switch 1-phase with overload protection.
8. Connection Box for 3-phase versions.
9. Cable and Plug for 1-phase versions.
10. Inlet Flange outside dia.199mm.
11. Legs 500mm.

## 1.4 Installation.

**2x160mm Extraction-Arms max.2m length (Flexi or Super-Max).**

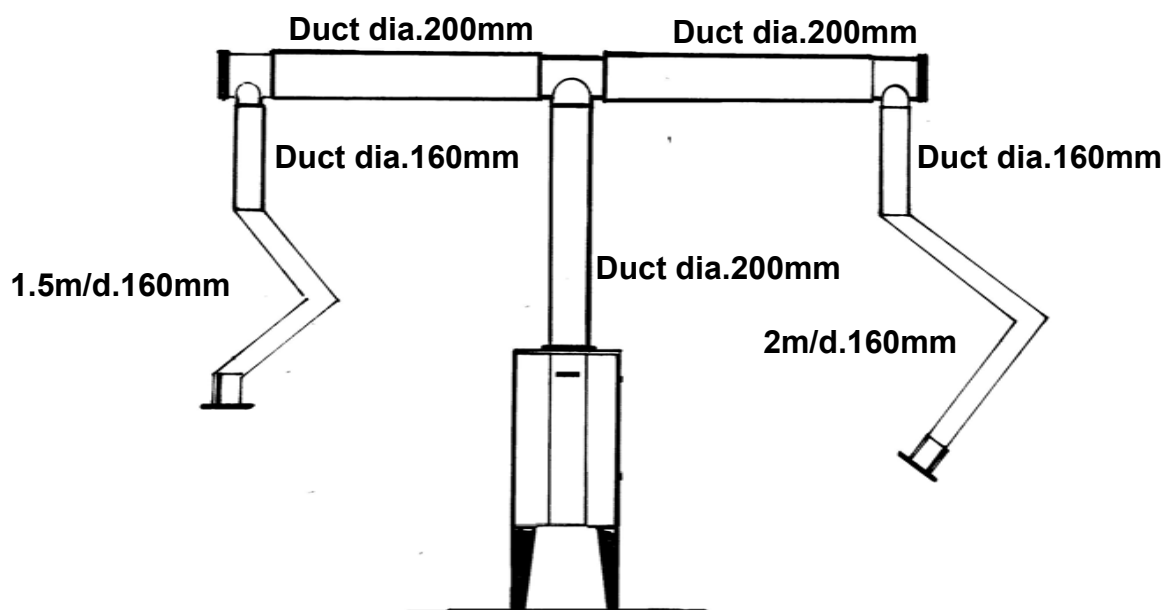

**4-8 dia.75 or dia.100mm Extraction-Arms (Flexa or Chemikus).**



**From CF Unit Vertical and Horizontal Ducting dia.200mm.  
From Horizontal Ducting to Extraction-Arm dia.75mm or 100mm.**

## 1.5 Change of Filter.

### CF-F9 Extractor-Filter

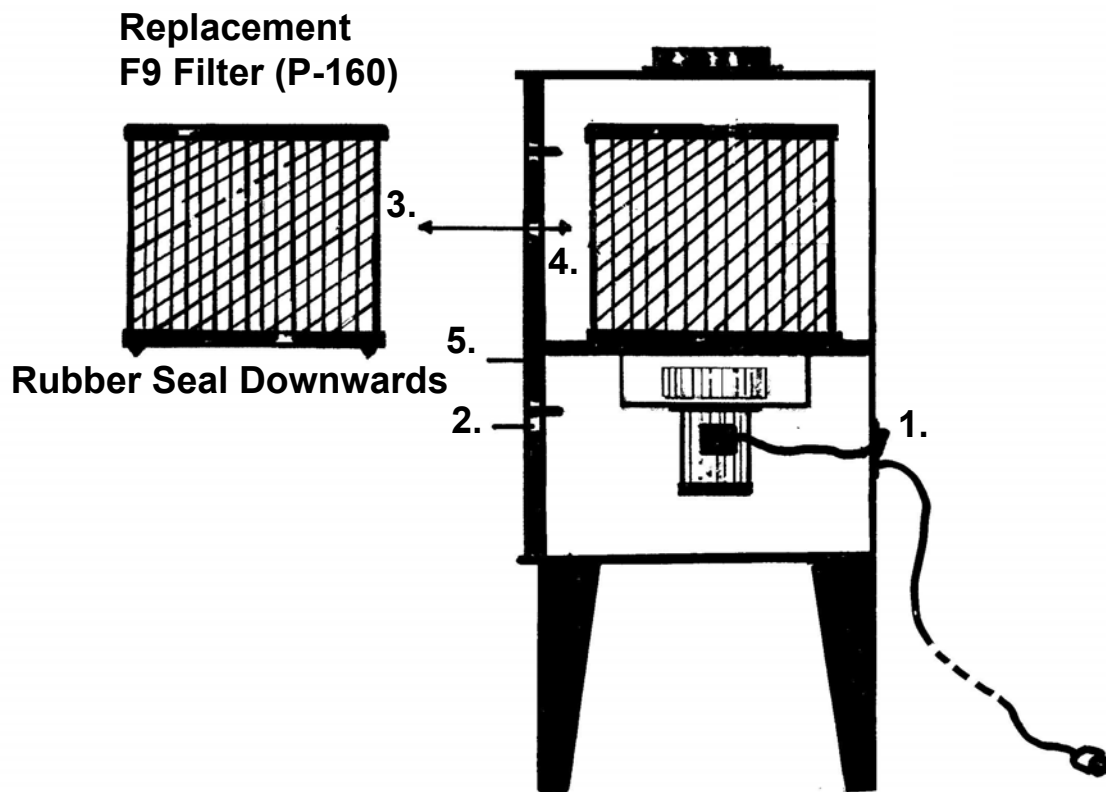

### Recommended Steps to replace the Filter.

1. Switch off the Fan on the Unit and disconnect the plug (1-Phase) or switch off the unit on where the Switch is mounted (3-Phase).  
Use adequate Safety Clothing!
2. Open the 4 Exenter Locks on the Door and lift it off. Place it in a safe place.
3. Pull out the old Filter.
4. Put in a replacement Filter with the Seal Downwards. Be sure it is centered around the inlet of the Fan.
5. Mount the Door and lock it with the 4 Exenter Locks.
6. The CF Extractor Filter is ready for use again.
7. Dispose of the old Filter according to Local Laws and Regulations.

## CF-HEPA Extractor-Filter.

### Prefilter Alu-Mesh

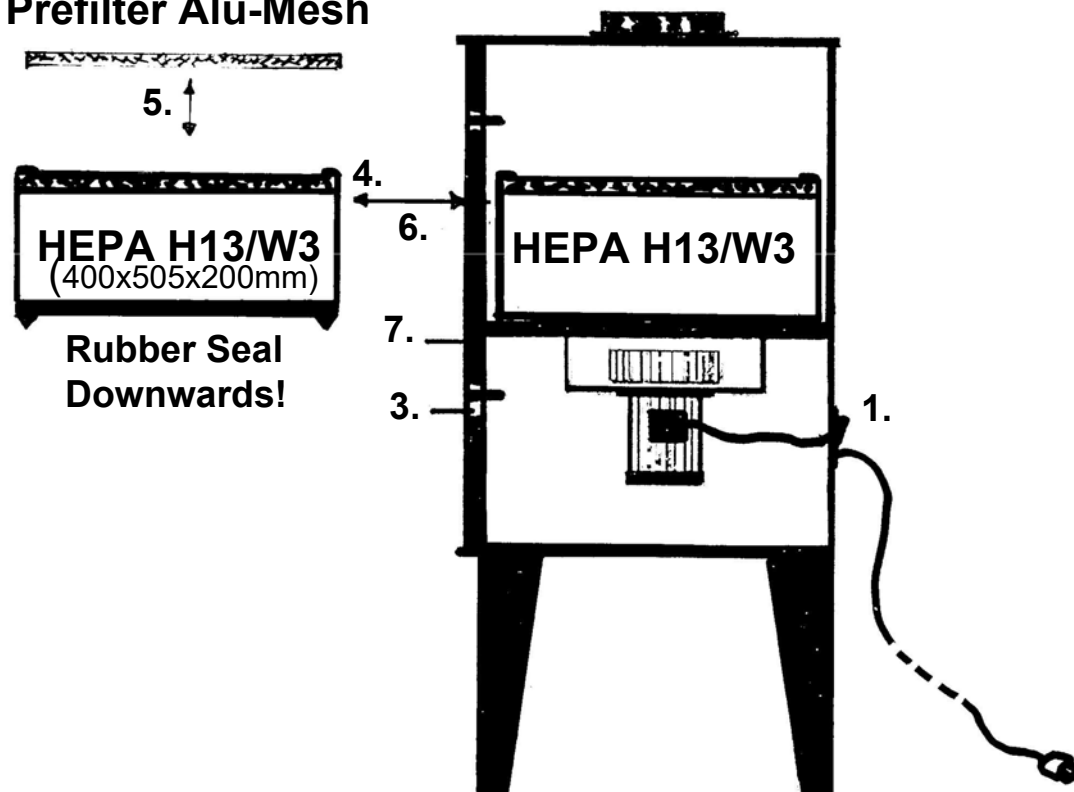

### Recommended Steps to change Filter.

1. Switch off the Fan on the Unit and disconnect the plug (1-Phase) or switch off the unit where the Switch is mounted (3-Phase).
2. Use adequate Safety Clothing!
3. Open the 4 Exenter Locks on the Door and lift it off. Place it in a safe place.
4. Pull out the Filter-Box.
5. Take out the Alu-Mesh Prefilter, wash it and put it back. Put in the Filter-Box and Lock the Door. Start the Unit and test if the extraction is good enough. If not see 6. below.
6. Take out the Filter Box again and replace it with a new. Note! The Seal Downwards!
7. Mount the Door and lock it with the 4 Exenter Locks.
8. The CF Extractor Filter is ready for use again.
9. Dispose of the old Filter according to Local Laws and Regulations.



## **2.0 Maintenance**

### **2.1 General Information.**

The CF Extractor-Filters are robust and normally don't need much maintenance. However the following should be checked at least 2 times a year.

- 1. Check that all bolts are tight.**
- 2. Check if the extraction is good enough. If not please see "1.5 Change of Filter" above. There is no Problem with changing from F9 Filter Cartridge to HEPA H13 Filter Box or vice versa, if the work situation has changed. You can also change to an Active Carbon Filter Cartridge(P-962) if needed.**
- 3. Check the Electric Cable. If there are damages on it, you have to change it. Use Plymoth original spare parts. A certified Electrician has to do the change.**
- 4. Check that the Extraction-Arms are easy to move and that they stay in position. If not tighten the friction joints.**

## 2.2 Spare Parts CF Extractor-Filters. (F9 and HEPA H13).

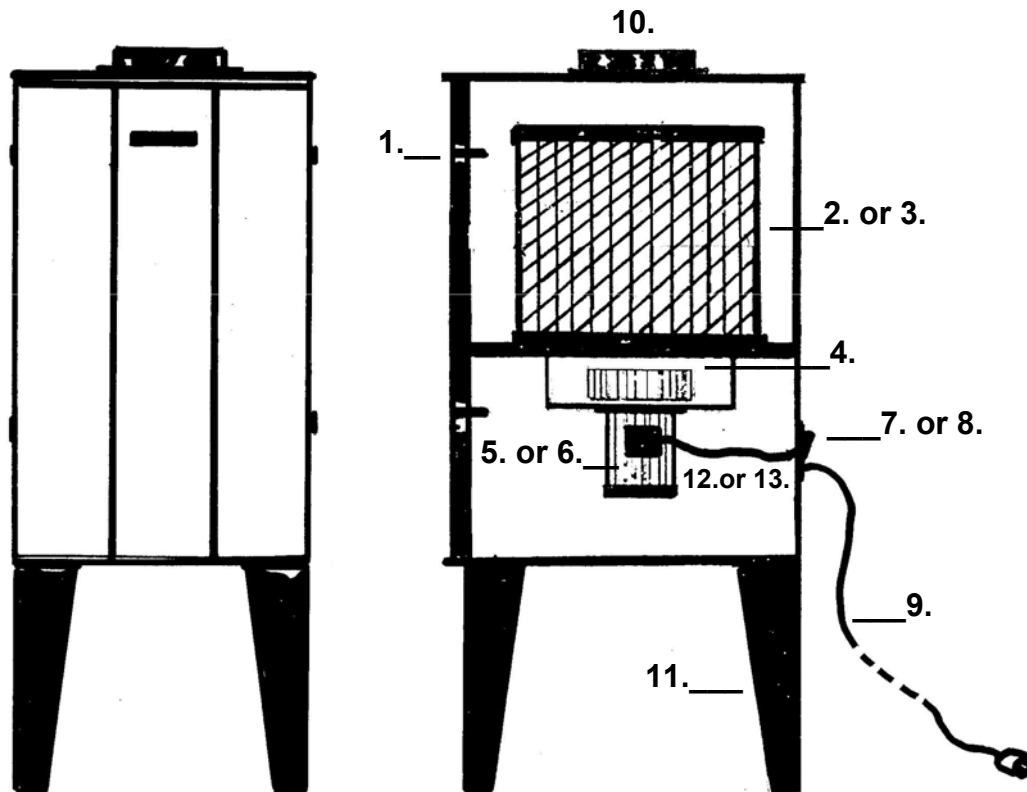

When ordering Spare Parts please specify:

- a. Name and P-number of Your Product.
- b. Number and Text from below.
- c. Quantity of each Spare Part.

1. Door with 4xExenter Locks. Complete.
2. F9 Filter Cartridge 12m<sup>2</sup> (P-160).
3. HEPA H13 Filter Box 9m<sup>2</sup> (P-577). 400x505x200mm.
4. Impellar.
5. Electric Motor 1-phase/1.1kw/220V/50Hz.
6. Electric Motor 3-phase/1.1kw/400V/50-60Hz.
7. On/Off Switch 1-phase with overload protection.
8. Connection Box for 3-phase (3-phase versions).
9. Cable and Plug for 1-phase versions.
10. Inlet Flange outside dia.199mm.
11. Legs 500mm.
12. Motor Cable 1-phase.
13. Motor Cable 3-phase.
14. Alu-Mesh Prefilter for HEPA H13 Filterbox (400x505x200mm).



### Declaration of conformity

We, J. Plymoth AB, declare under our sole responsibility that the product lines **MF-F9/HEPA, MF-Active Carbon, MF-Eco/F9, MF-Eco/HEPA, MF-Filter-Tables, MF-Eco Filter-Tables, FK-Mesa Backdraft Filter-Tables, MKF Filter-Tables, Labbe, CF-Lab, CF-Eco Lab, CF Central Filters, Mobo-Oil, Denta-Flex, Fica-Flex and VBF-Office** to which this declaration relates is in conformity with Directives 2006/42/EC, 2014/30/EU, 2011/65/EU and Standards EN 60204-1:2006, EN ISO 12100:2010, EN ISO 15012-1:2013, EN 61000-6-2:2005, EN 61000-6-3:2007, EN ISO 20607:2019.

J. Plymoth AB  
Traryds Allen 4D  
28772 Traryd

87

  
Jenny Nilsson  
Verkställande Direktör

2023-01-01