

User Manual

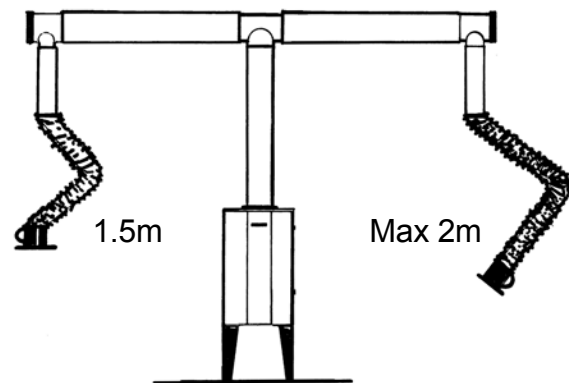

CF-Eco with dia.160mm Extraction-Arms



CF-Eco with dia. 75mm and 100mm Extraction-Arms



CF-ECO Extractor-Filter with F9 or F9+HEPA H13 Filter.

The F9 Filter-Cartridge has a built in Compressed Air Cleaning System.

- Extractor-Filter for 1-2 dia.160mm or 4-8 dia. 75/100mm Extraction-Arms.
- Models with F9 Filter-Cartridge (.. m2) or F9+HEPA H13/W3 Filter (9m2).
- F9 Models are suitable for filtration of Light Welding-Fume and Dust.
- F9+HEPA H13 Models are for Light Stainless Steel-Fume and Fine Dust.
- Can be changed from F9 Filter to HEPA H13 Filter When/If needed.
- The Jet-Pulse cleaning systems can clean the F9 Filter-Cartridge up to 100 times before it needs to be replaced.
- Initial Extraction volume 1400-1800m³/h.
- 1-Phase or 3-Phase models.

Table of Contents

1.0 General Information

1.1 Safety Note

1.2 Range of Application

1.3 Unite Description

1.4 Installation

1.5 Change of Filter

2.0 Maintenance

2.1 General Information

2.2 Spare Parts

1.0 General Information.

A CF-ECO/F9 or CF-ECO/F9+HEPA H13/W3 Extractor-Filter and 1-2 d.160mm Extraction-Arms is an easy way to create a work place with clean air for light Welding and Grinding.

For Contaminated air generated over a smaller spot area you can connect 4-8 dia.75mm or 100mm Extraction-Arms. Perfect for Soldering and light Dust.

The F9 Filter-Cartridge(9m²) can be cleaned up to 100 times with the built in Jet-Puls Cleaning System. Keeps Filter Costs down.

A CF-ECO Extractor-Filter System is simple to install. Mount the Extraction-Arm/ Arms on the wall. Mount dia.160mm or dia.75/100mm ducts upwards to a dia.200mm Horizontal Ducting. Let it go to an area where the CF-ECO Unit can be placed. Go down with a dia.200mm Duct to the CF-LAB. Bolt the unit to the floor and just plug it into an electric socket (single phase models) or let a certified electrician install it (3-phase Models). Ready for use!

CF-ECO Extractor-Filters are perfect for Laboratories and Schools.

The models with F9 Filter-Cartridge (9m²)+HEPA H13/W3 Filter Box (9m²) are suitable for Light Stainless Steel Welding Fume and Fine Dust. The Cleanable F9 Filter works as a Prefilter and will prolonge the lifetime of the HEPA Filter.

The Door has 4 expander locks to make it easy to open and lock.
4 locks make sure that the door is tight.

To replace the HEPA H13 Filter Box you open the door and just pull the box out. Test if the extraction will be good enough if you change the prefilter, located in the top of the HEPA Filter Box. If the extraction is still not good enough you have to replace the HEPA Filter Box.

1.1 Safety Note.

Always disconnect the electricity supply before opening the CF-Unit.

Don't exhaust Sparks or Poisenous Dust.

Use adequate safety clothing when replacing dirty filters.

Dispose of used Filters according to local laws and regulations.

1.2 Range of Application.

The CF-ECO Extractor Filter is designed for work situations where smaller amounts of fume and dust is generated. The F9 model has a filtration efficiency of 99% and the HEPA H13 of 99.95%. The filtered air can be recirculated into the the room as long as it is not against local laws and regulations.

1.3 Unit Description.

CF-ECO/F9 and CF-ECO/F9+HEPA H13 are Complete Units with Fan and Filter. They have a built in Jet-Puls Cleaning System for the F9 Filter. Possible to clean up to 100 times Suitable for 1-2 Flexi Extraction-Arms d.160mm, or 4-8 Flexa/Chemicus Extraction-Arms dia.75mm or 100mm.

CF-ECO F9 Jet-Pulse. Light Welding/Soldering Fume.

CF-Eco F9 Jet-Pulse is made for light welding/soldering fume and light dust. It is equipped with Jet-Pulse cleaning for the F9 cartridge filter (9m²) and built in fan with aluminium impeller. The air volume at the diameter 199mm inlet is ca.1400m³/h.

Jet-Pulse Cleaning of F9 Cartridge.

CF-Eco F9 Jet-Pulse has a built in pneumatic cleaning system. When the extraction volume has become too low you clean the Cartridge with the Jet-Pulse. Takes just a few minutes. Then take out the dust bin and empty it. The CF-ECO is now back to normal Extraction volume again.

CF-ECO HEPA H13/W3 Jet-Pulse. Stainless Steel Welding.

CF-Eco HEPA H13/W3 is designed as CF-Eco F9 Jet-Pulse but has a HEPA H13/W3 Filter Box (9m²) after the F9 Filter. It can be used for light stainless steel welding/soldering. The F9 cleanable Filter Cartridge works as a Pre-Filter and will increase the life time of the HEPA Filter. When the extraction is too low, even after cleaning the F9 Pre-Filter Cartridge, it is time to replace the HEPA filter.

Soldering/Light Welding.

1-2 Flexi d.160mm Extraction Arms or 4-8 Flexa/Chemikus Extraction Arms d. 75-100mm can be connected to the CF-Eco. The inlet diameter is 200mm. Use d.200mm Vertical/Horizontal ducting from the CF and go down with 160mm duct alternatively 75/100mm duct to the Extraction Arms. Ask our specialists for advice.

40 Years Experience!

The Plymoth products are a combination of well-proven technique and progressive new ideas. Plymoth is always a step ahead - but not expensive!



	Art. No.
CF-ECO/F9 Jet-Pulse. 1-Phase/1.1kW/220V/50Hz. F9 Filter (9m ²) 0.5m Legs.	P-560
CF-ECO/F9 Jet-Pulse. 3-Phase/1.1kW/400V/50Hz. F9 Filter (9m ²) 0.5m Legs.	P-561
CF-ECO/F9+HEPA H13/W3 Jet-Pulse.1-Phase/1.1kW/220V/50Hz. HEPA (9m ²). Legs.	P-968
CF-ECO/F9+ HEPA H13/W3 Jet-Pulse. 3-Phase/1.1kW/220V/50Hz. HEPA (9m ²). Legs.	P-969
F9 Replacement Filter Cartridge 9m ² . For ALL ECO MODELS (300mm high).	P-541
HEPA H13/W3 Filter Box 9m ² . For MF-ECO, CF-ECO, CF-ECO LAB.	P-544

1.3.1 Jet-Pulse Cleaning System.

JET-Pulse Cleaning System

The **Jet-Pulse cleaning** system is developed in the United states for cleaning of filter cartridges. It is considered better than ordinary "Back-Pulse" cleaning systems. The **Jet-Pulse cleaning** is faster and more efficient.

The heart of the **Jet-Pulse cleaning** system is a specially designed oscillating rubber nozzle. It is oscillating under 6 Bar compressed air pressure inside the filter cartridge. It is hammering the inside of the filter cartridge so that dust on the surface is falling off. At the same time it is blowing out the fine dust which has penetrated the surface of the filter cartridge. The result is a cartridge as clean as new.

Explosion safety.

To minimise the risk of explosions in a filter unit many countries have now laws saying you have to empty the dust bin after every cleaning. The CF-ECO Extracor-Filter Units with built in **Jet-Pulse Cleaning** Systems have all a lightweight dustbin which is very handy and fast to empty after the cleaning process.

As an extra safety feature all ECO Filter units have the electrical parts outside the unit to avoid that electricity gets in contact with dust or gas.

1. Rubber Nozzle.
2. Compressed Air Valve.
3. Compressed Air Hose.
4. F9 Filter Cartridge.
5. Dust Bin.
6. Dust.

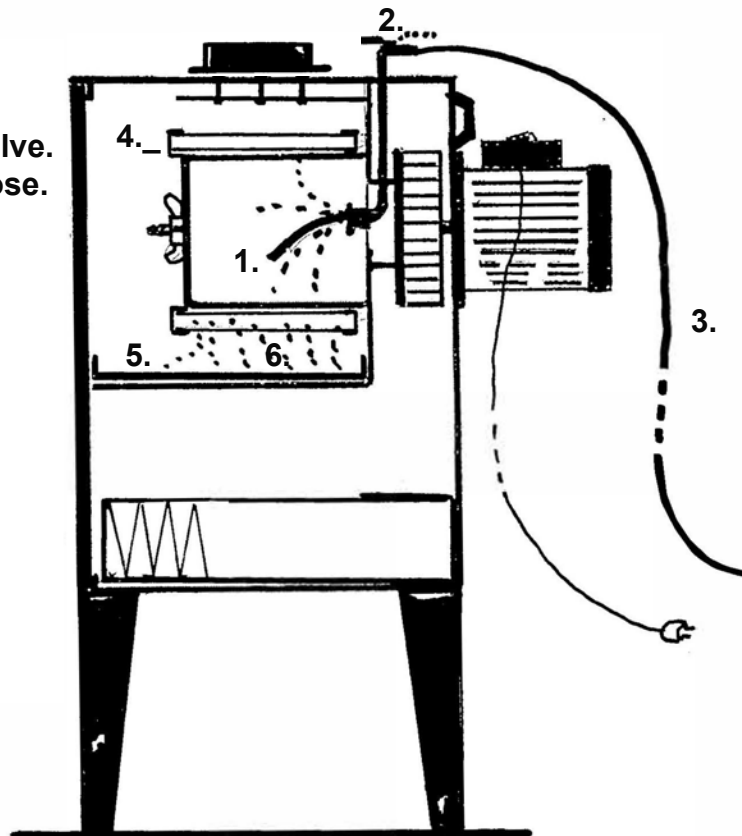

1.3.2 CF-ECO/F9 and CF-ECO/F9+HEPA H13/W3. Jet-Pulse Cleaning of the F9 Prefilter.

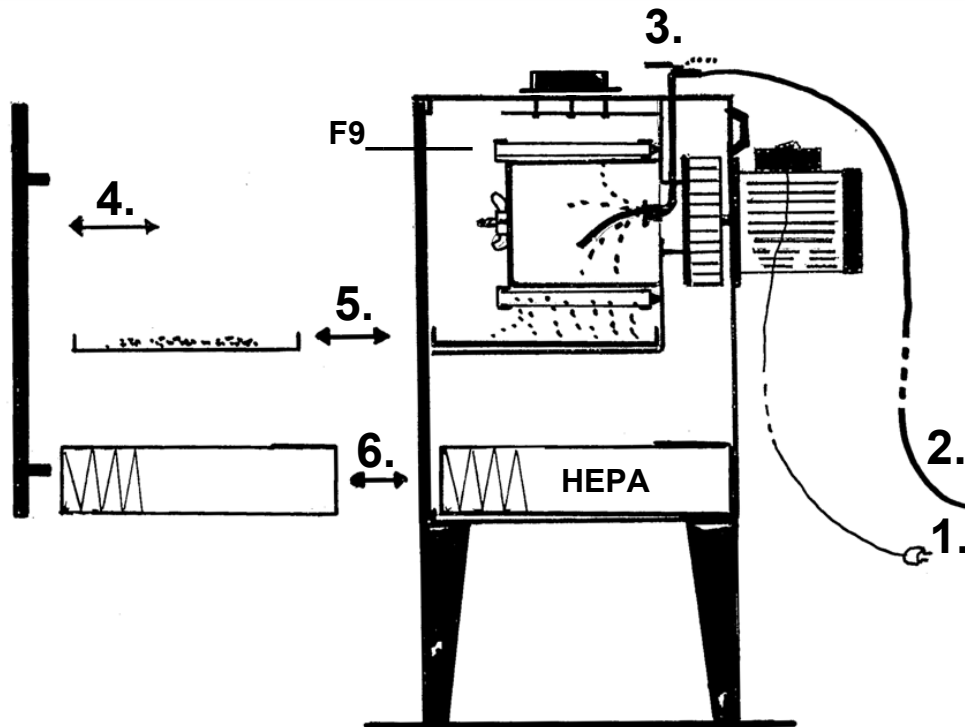

When the extraction is not good enough you clean the F9 Filter Cartridge with the built in compressed air cleaning system.

1. Take the electric plug out of the wall.
2. Connect the hose to compressed air. 5-6 Bar. Not more not less.
3. Open the valve on top of the unit SLOWLY. When open count to 10 and close the valve quickly. Repeat 3 times with at least 30 seconds between.
4. Wait a couple of minutes and then open the door.
5. Pull out the tray with the dust. Empty it according to local regulations for the type of dust you have extracted.
Put the dust tray back in place and mount the door.

During the cleaning process some smoke/dust can come out of the hood of the extraction-arm. It is the same for all compressed air cleaning systems. To have the hood close to the floor helps.

The extraction power is now back to almost the same as for a new F9 Filter Cartridge. Depending on how the CF-Eco is used you can clean 50-100 times before the cartridge needs to be replaced.

6. If the extraction, after cleaning the F9 Prefilter not is back to an acceptable level, you may have to replace the HEPA Filter Box.
Please see "1.5 Change of F9 and HEPA Filter"

1.3.3 CF-ECO Measures.

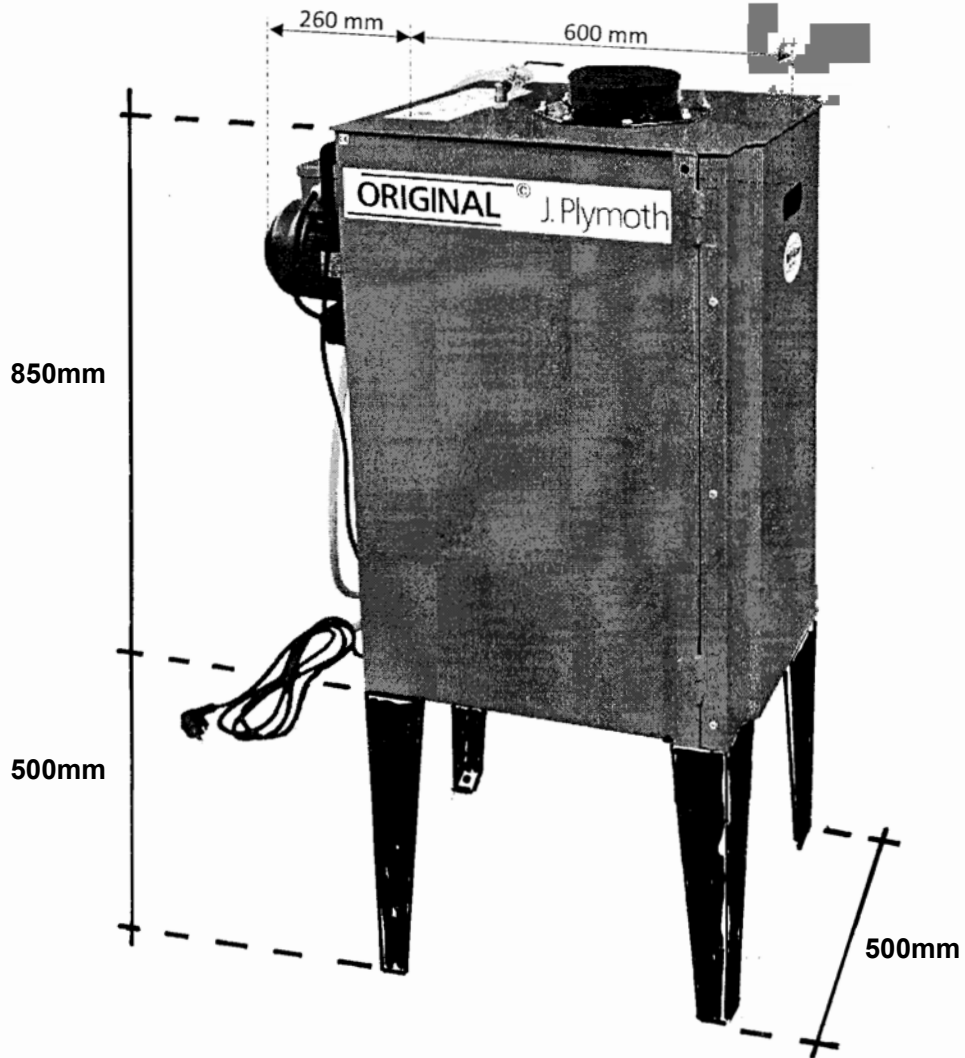

Techical Data		
Volt/Phase	230 Volt / 1~	400 Volt / 3~
KW	1.1 kW	1.1 kW
Ampere	6.53 A	2.3 A
Revolutions/minute	2.900 R/min	
Frequency	50Hz	
	IP 55	
Weight	70 kg	
Filter	Filter Cartridge F9 (9m ²)	
Extra Equipment HEPA Filter	HEPA H13 Filter Box (9m ²)	
Efficiency	>99 % (HEPA 99.95%)	
Noice level (DIN 45635 T1)	ca. 70 dB(A)	
Indoor temperature	+5° C bis +35° C	

1.4 Installation.

2x160mm Extraction-Arms max.2m length (Flexi or Super-Max).

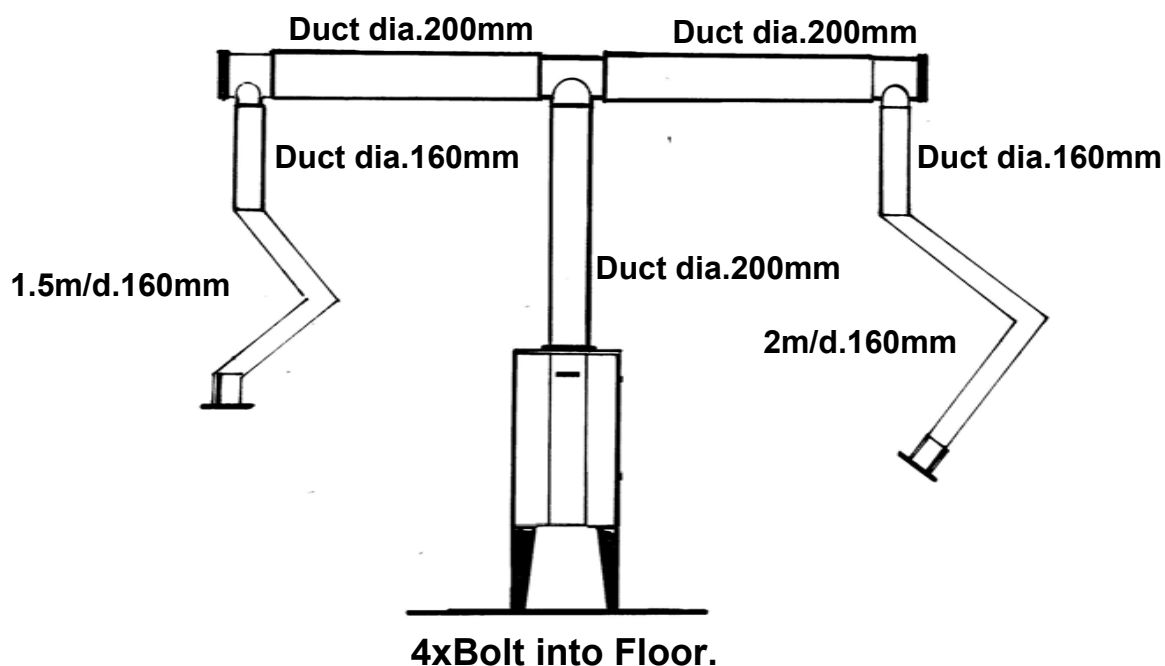

4-8 dia.75 or dia.100mm Extraction-Arms (Flexa or Chemikus).



Ducting from the CF-ECO Unit. For Vertical and Horizontal ducting use dia.200mm Duct. From Horizontal Ducting to Extraction-Arms use dia.75mm or 100mm Duct.

1.5 Change of F9 and HEPA H13/W3 Filters.

Use adequate Safety Clothing when changing Filters. Used Filters have to be taken care off according to local regulations and laws.

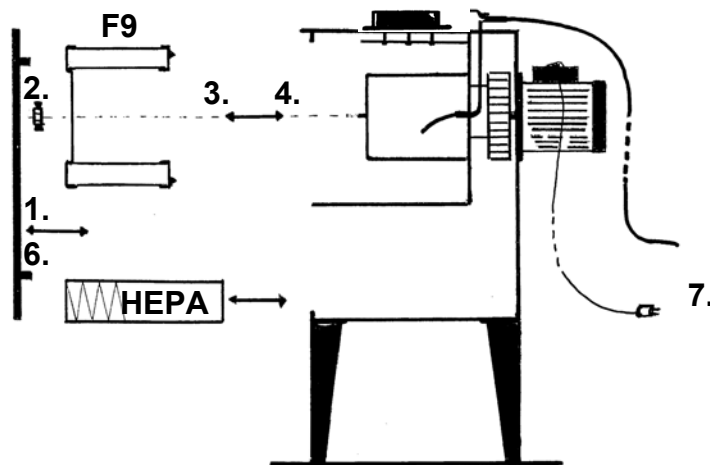

When the Extraction is not good Enough after Cleaning the F9 Filter Cartridge, or there are holes in it, you need to replace it with a new (P-541).

Switch off the Fan! (Take out the Plug).

1. Take off the Door.
2. Loosen Wing Nut.
3. Pull out the F9 Filter Cartridge.
4. Put in a Replacement F9 Filter Cartridge (P-541).
5. Mount the Wing Nut (2.) and tighten it. Be sure that the seal of the Cartridge is tight.
6. Mount the Door.
7. Connect the plug to the electric contact. Switch the CF-Eco on again.

If the CF-ECO is equipped with a HEPA Filter Box, and the extraction is not good enough after you have cleaned the F9 Filter you need to replace the HEPA Filter.

Switch off the Fan! (Take out the Plug).

1. Take off the Door.
2. Pull out the HEPA Filter Box.
3. Put in a replacement HEPA Filter Box (P-544) with the Seal Downwards!
4. Mount the Door.
5. Connect the Plug to the electric contact. Switch the CF-ECO on again.

2.0 Maintenance.

2.1 General Information.

The CF-ECO Extractor-Filters are robust and normally don't need much maintenance. However the following should be checked at least 2 times a year.

- 1. Check that all bolts are tight.**
- 2. Check if the extraction is good enough. If not please see:**

"1.5 Change of F9 and HEPA H13/W3 Filters".

It is no Problem to equip a CF-ECO/F9 with a HEPA H13 Filter Box if the work situation has changed.

- 3. Check the Electric Cable. If there are damages on it, you have to change it. Use original spare parts. A certified Electrician has to do the change.**
- 4. Check that the Extraction-Arms are easy to move and that they stay in position. If not tighten the friction joints.**

2.2 Spare Parts CF-ECO Extractor-Filters. (F9 or F9+HEPA H13).

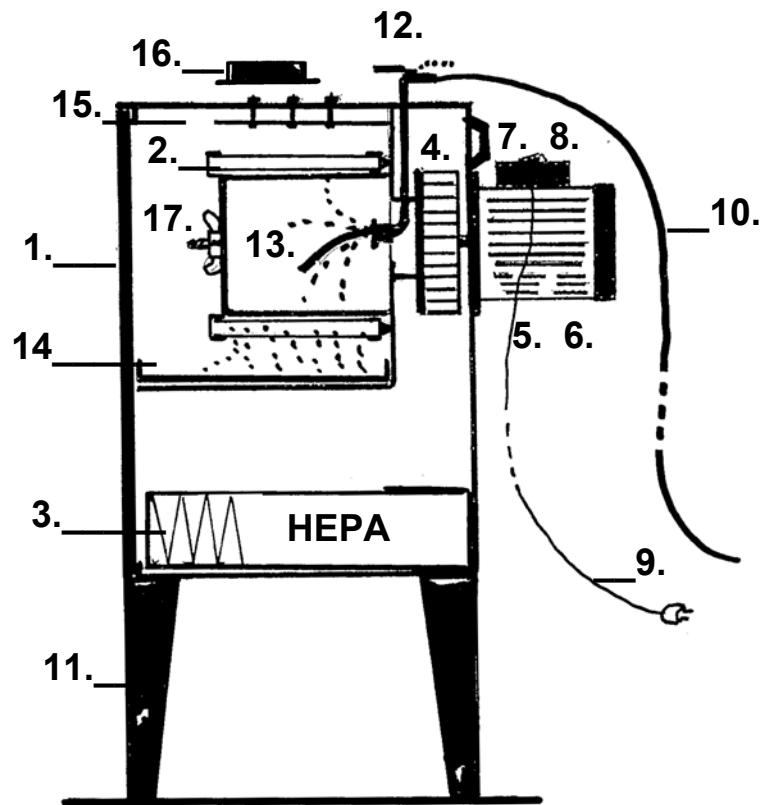

When ordering Spare Parts please specify:

- a. Name and P-number of Your Product.**
- b. Number and Text from below.**
- c. Quantity of each Spare Part.**

- 1. Door with 4xExenter Locks. Complete.**
- 2. F9 Filter Cartridge 9m2.**
- 3. HEPA H13 Filter Box 9m2.**
- 4. Impellar.**
- 5. Electric Motor 1-phase/1.1kw/220V/50Hz.**
- 6. Electric Motor 3-phase/1.1kw/400V/50-60Hz.**
- 7. On/Off Switch 1-phase with overload protection.**
- 8. On/Off Switch with overload protection for 3-phase.**
- 9. Cable and Plug for 1-phase versions.**
- 10. Compressed Air Hose.**
- 11. Leg 0.5m.**
- 12. Compressed Air Valve.**
- 13. Rubber Nozzle complete.**
- 14. Dust Bin.**
- 15. Inlet Sparktrap/Shield Complete.**
- 16. Inlet dia.199mm.**
- 17. Wing Nut M10.**



Declaration of conformity

We, J. Plymoth AB, declare under our sole responsibility that the product lines **MF-F9/HEPA, MF-Active Carbon, MF-HEPA/W3 18M2, MF-Eco/F9, MF-Eco/HEPA, MF-Filter-Tables, MF-Eco Filter-Tables, FK-Mesa Backdraft Filter-Tables, MKF Filter-Tables, Labbe, MF-Lab, MF-Eco Lab, CF Central Filters, Mobo-Oil, Denta-Flex, Fica-Flex and VBF-Office** to which this declaration relates is in conformity with Directives 2006/42/EC, 2014/30/EU, 2011/65/EU and Standards EN 60204-1:2006, EN ISO 12100:2010, EN ISO 15012-1:2013, EN 61000-6-2:2005, EN 61000-6-3:2007, EN ISO 20607:2019.

J. Plymoth AB
Traryds Allen 4D
28772 Traryd

Jenny Nilsson
Verkställande Direktör

2023-01-01